

Quantum electro-mechanics: a new quantum technology

Konrad Lehnert

Post-docs

Tauno Palomaki

Tobias Donner

Joseph Kerckhoff

Collaborators

John Teufel

Cindy Regal

Ray Simmonds

Kent Irwin

Graduate students

Jennifer Harlow

Reed Andrews

Hsiang-Sheng Ku

William Kindel

Adam Reed

Precision measurement tools were once mechanical oscillators

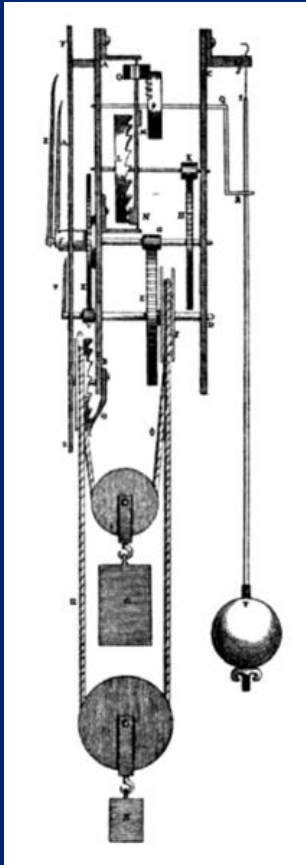

Huygens pendulum clock

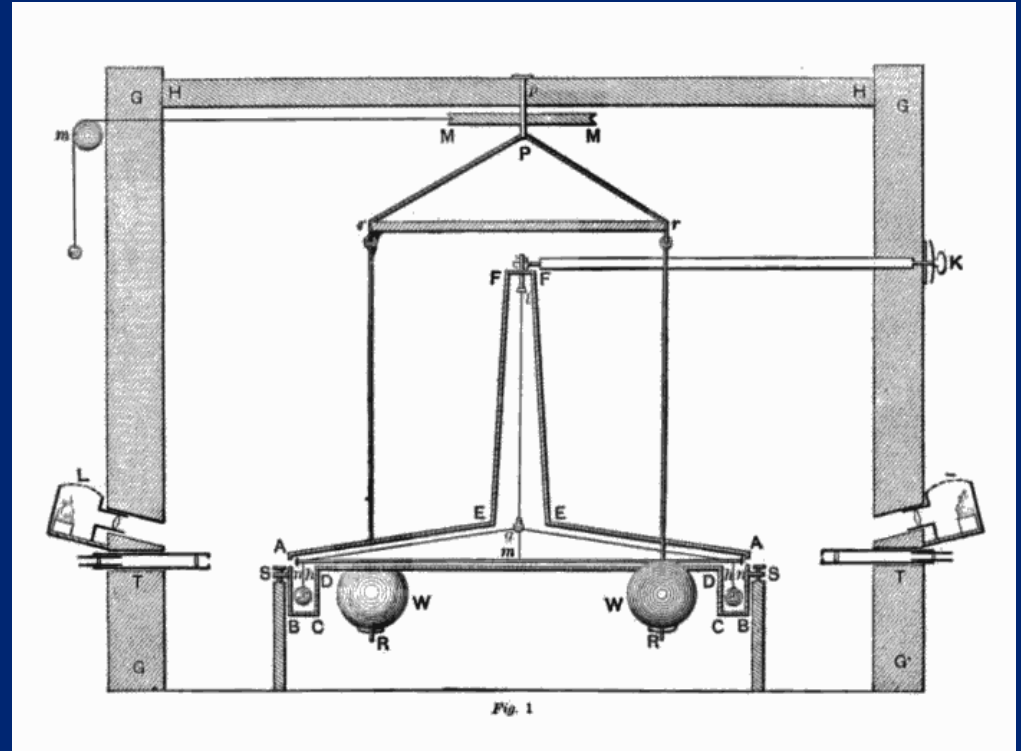

The Cavendish balance
for weighing the earth

Modern measurement tools exploit optics and electronics, not mechanics

Laser light

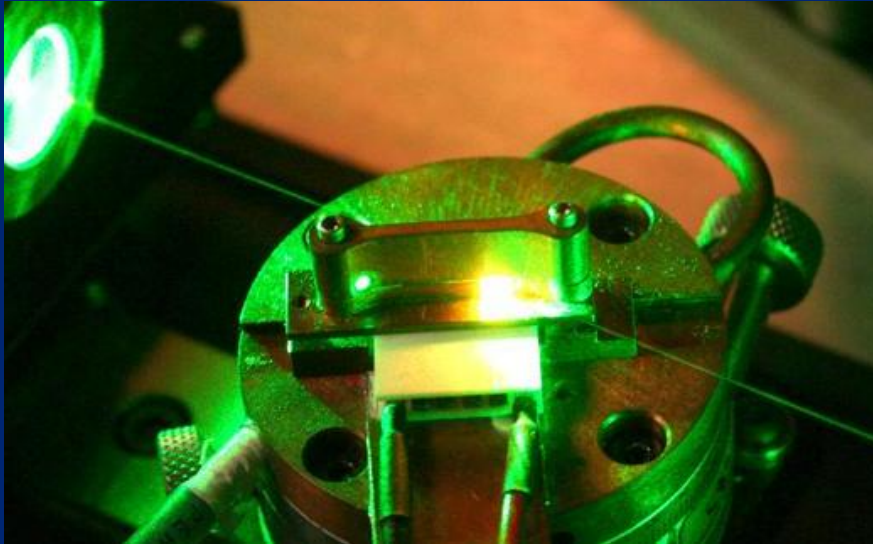
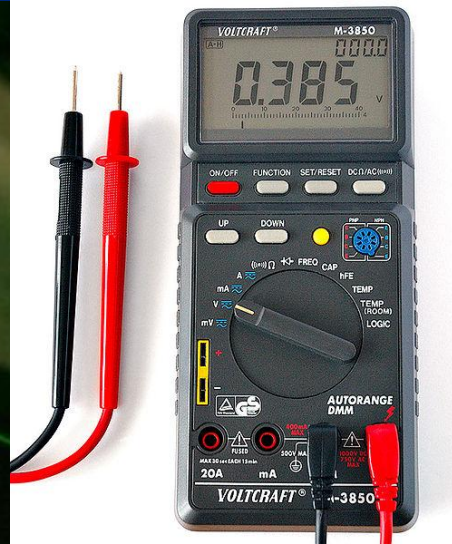

Image: Cundiff lab JILA

electricity



Optical and electrical measurement tools:
Large dynamic range

Optical probes are ill-suited to directly measuring many interesting systems

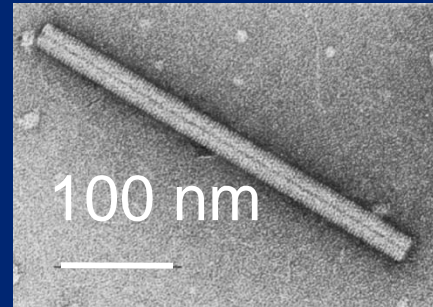
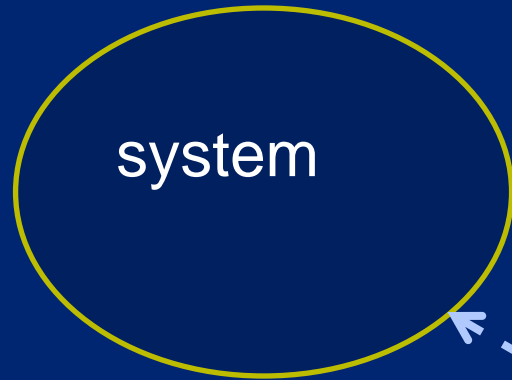

nuclear spins in
a virus
(Rugar lab, IBM)

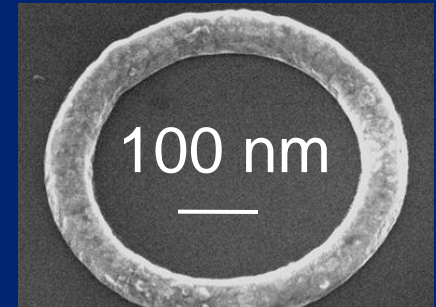

electrons in an
aluminum ring
(Harris lab, Yale)

Systems with:

- dense low-energy spectra
- nanometer length scales
- weak coupling to light

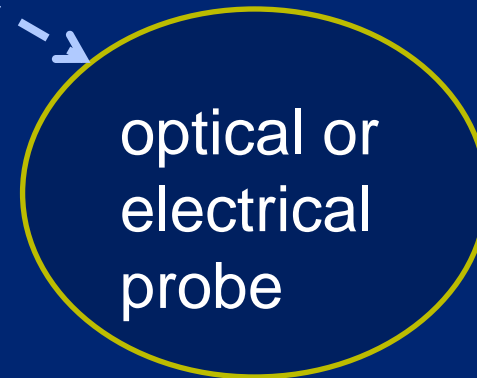

Mechanics enables measurements of systems that interact weakly with light

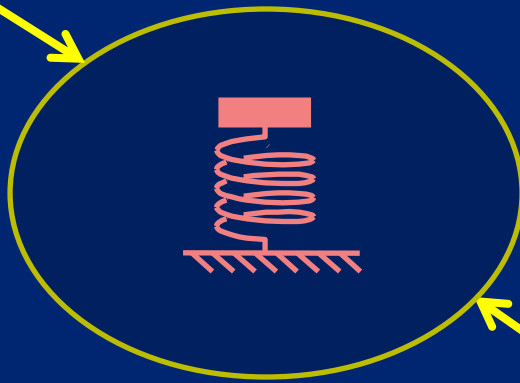
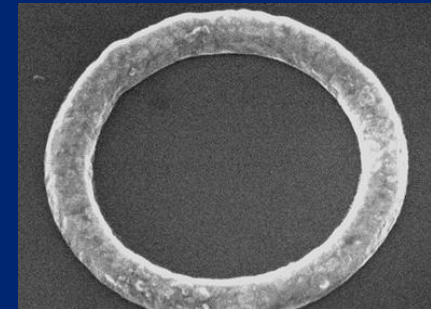
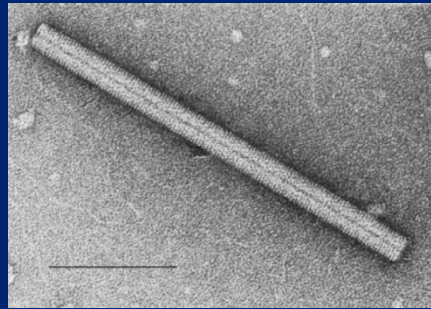
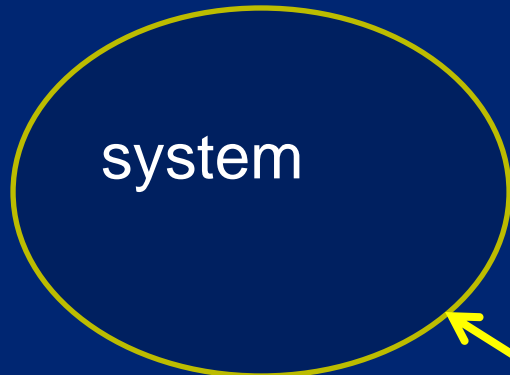

mechanical intermediary



Systems with:
dense low-energy spectra
nanometer length scales
weak coupling to light

Mechanical oscillators as quantum coherent interfaces between incompatible systems

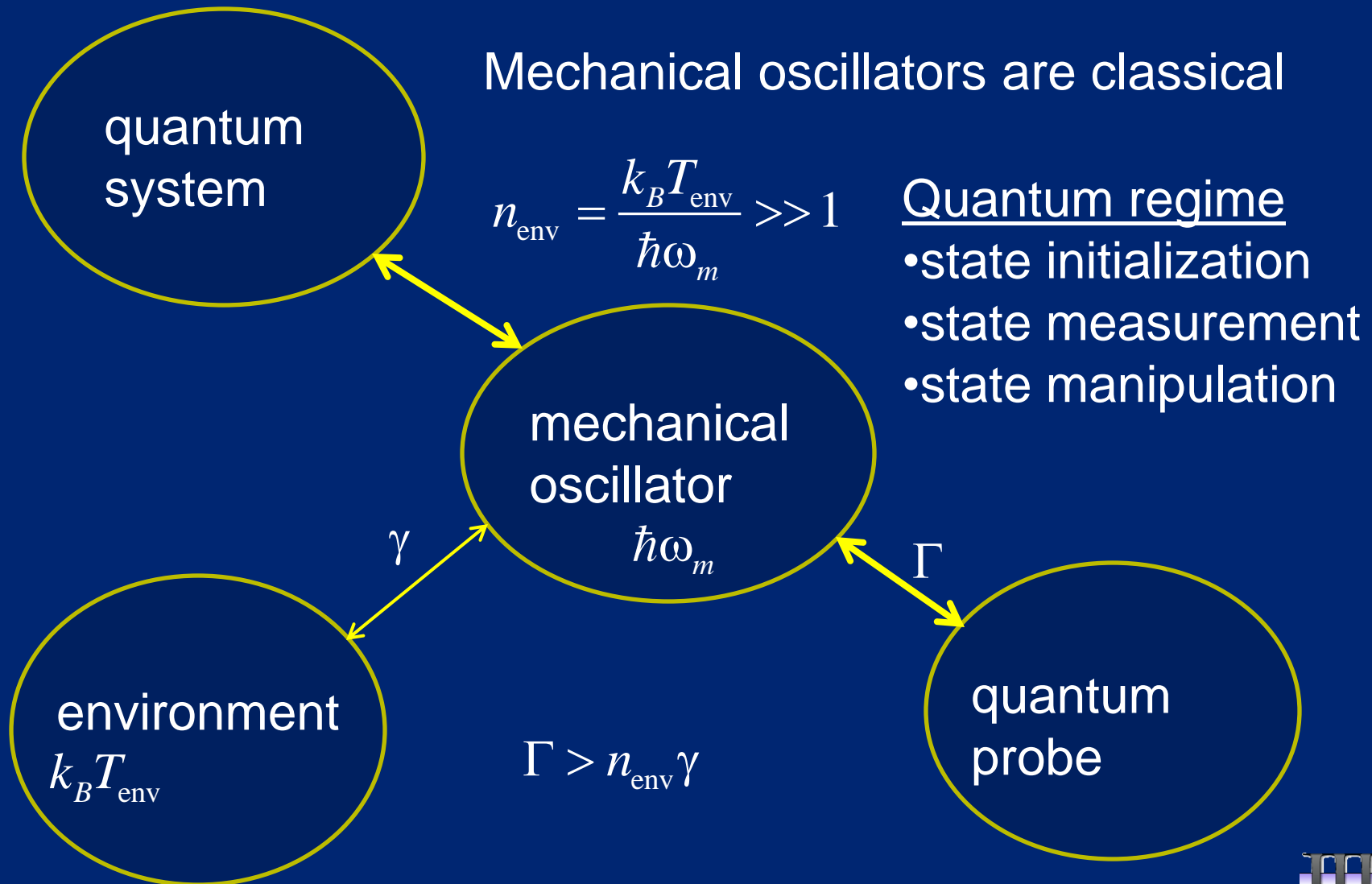

What is the largest object in which quantum behavior can be observed?

quantum
superposition

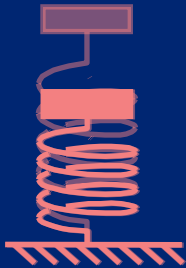

Mechanical oscillator
large
tangible

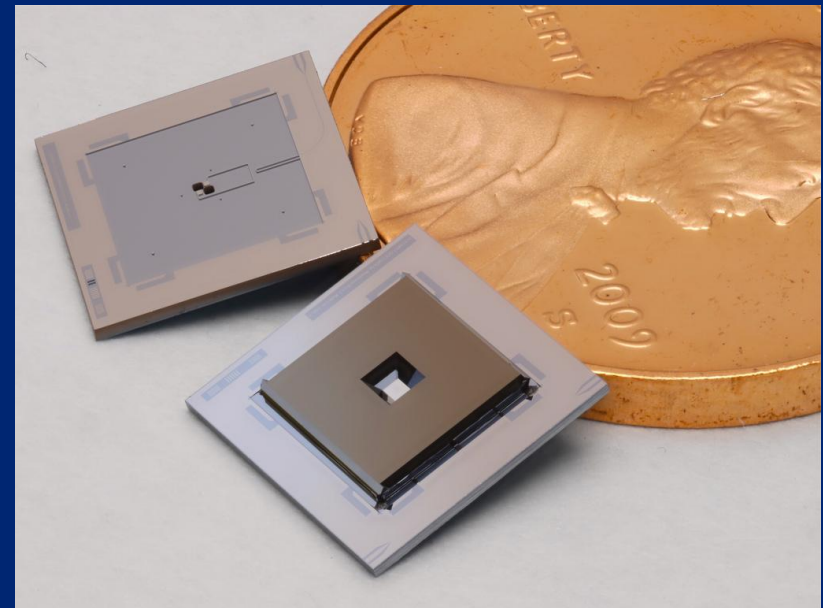

Cavity optomechanics: Use radiation pressure for state initialization and measurement

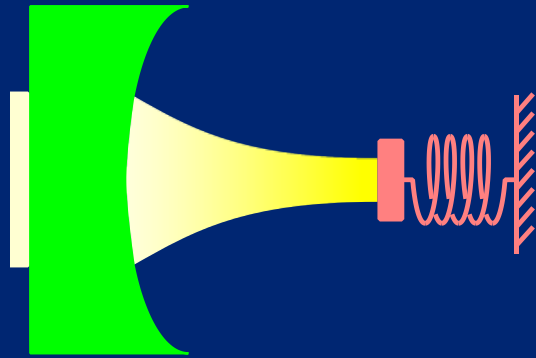

Fabry-Perot cavity with oscillating mirror

Infer motion through optical phase

Cool with cavity-retarded radiation force

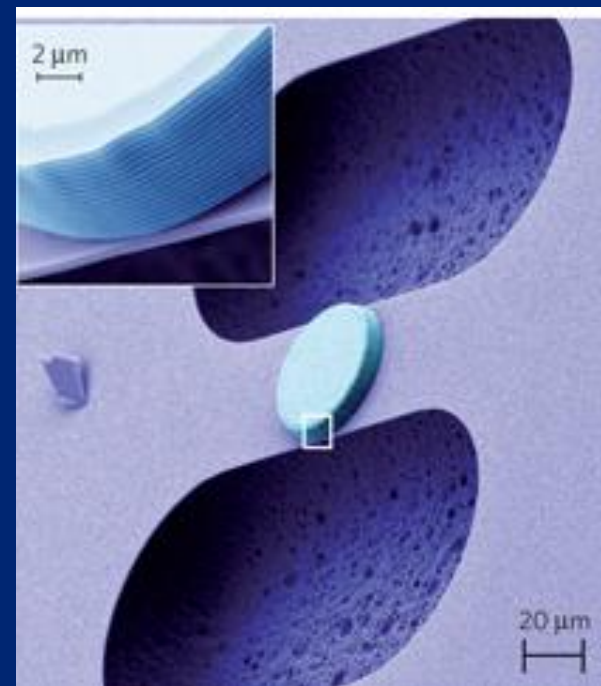

Images of cavity optomechanical systems

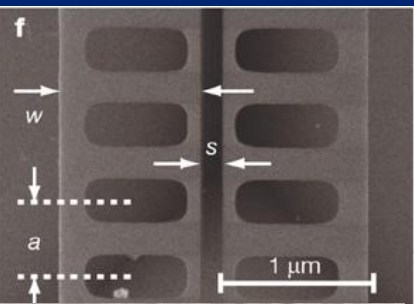

Caltech, Painter

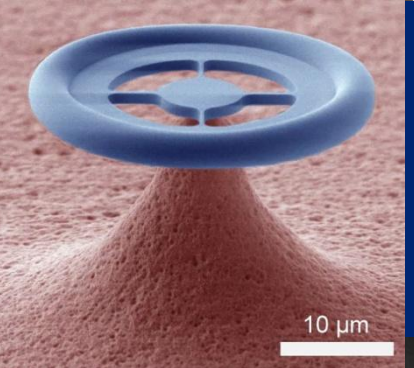

EPFL, Kippenberg

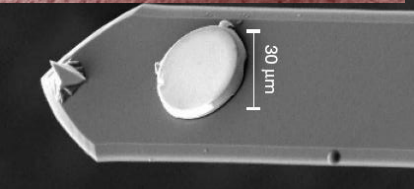

UCSB: Bouwmeester

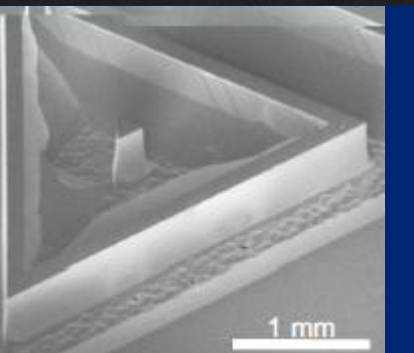

ENS: Cohadon and Heidmann

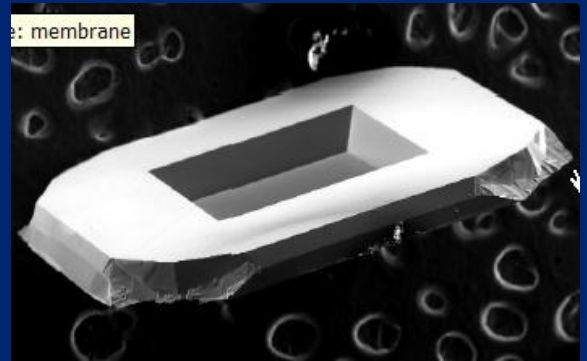

Yale, Harris



MIT, Mavalvala

Microwave cavity optomechanics

Reduce coupling to the environment by lowering temperature: microwave optomechanics

Microwave “light” in ultralow temperature cryostat

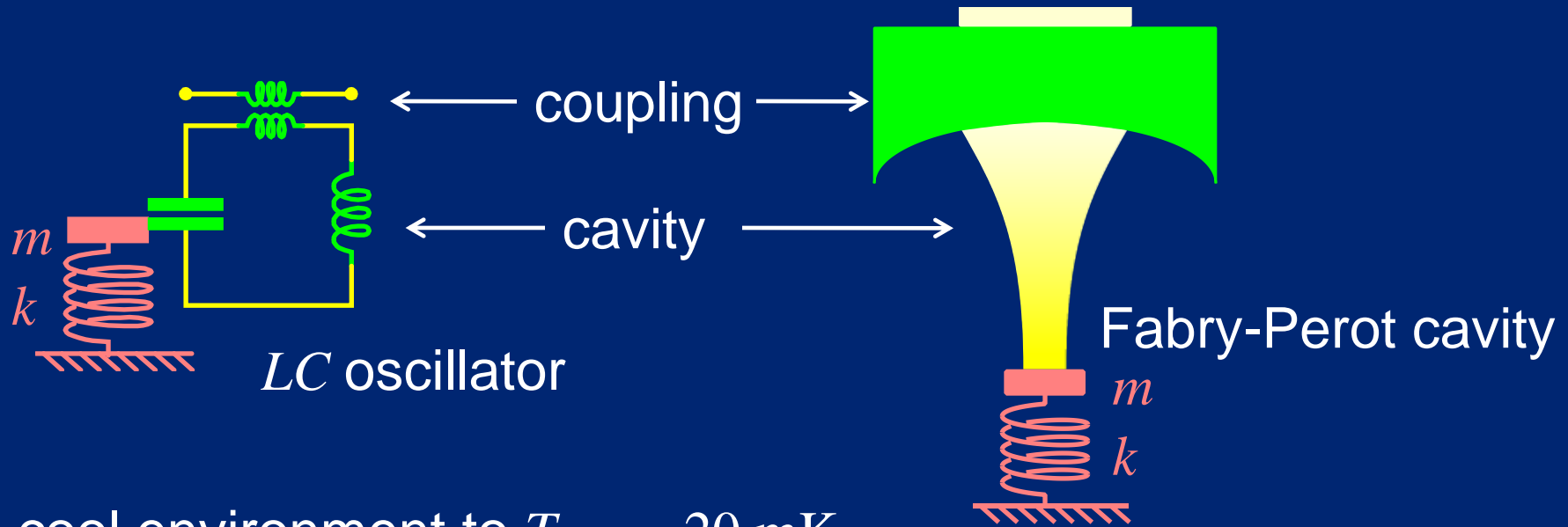

cool environment to $T_{\text{env}} = 20 \text{ mK}$

for 10 MHz oscillator $n_{\text{env}} = 40$

goal: $\Gamma > n_{\text{env}} \gamma$

Superconducting electromechanics used in resonant mass gravitational wave detectors

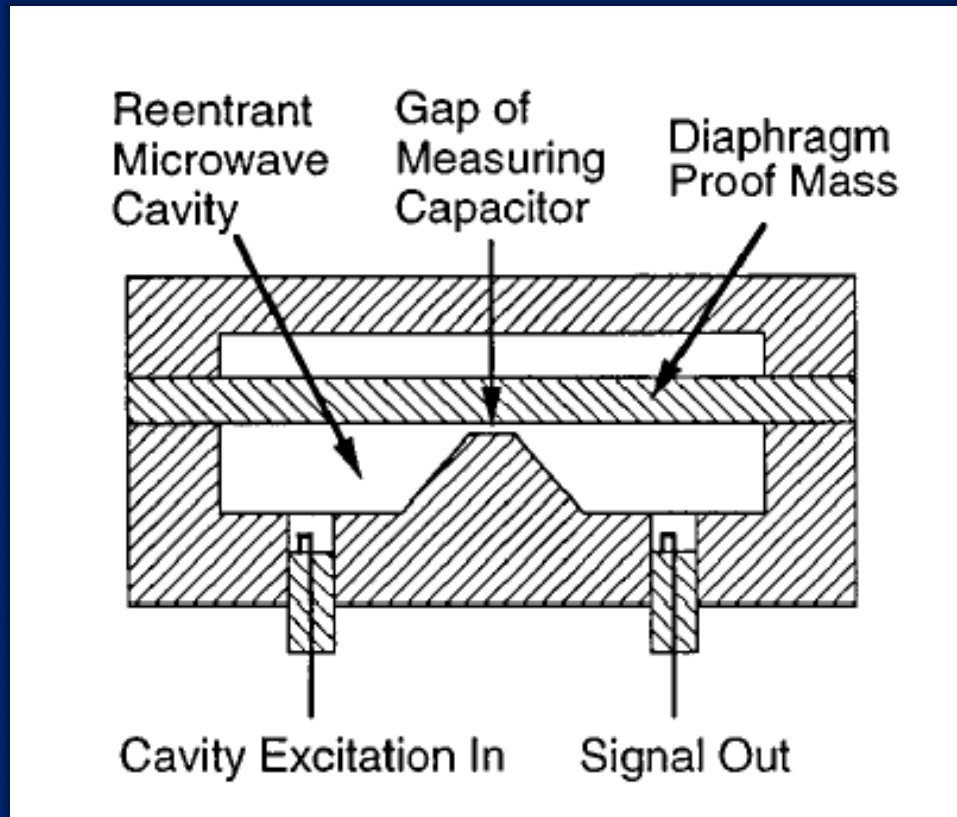

centimeter sized
superconducting cavity
with mechanically
compliant element

Braginsky, V. B., V. P. Mitrofanov, and V. I. Panov, 1981, *Sistemi s maloi dissipatsiei (Nauka, Moscow)* [English translation: *Systems with Small Dissipation (University of Chicago, Chicago, 1985)*].

Resonant electromechan

Soviet passive bug hidden in the



Henry Cabot Lodge, Jr. May 26, 1953
in the UN

Images appear in http://www.spybusters.com/Great_Seal

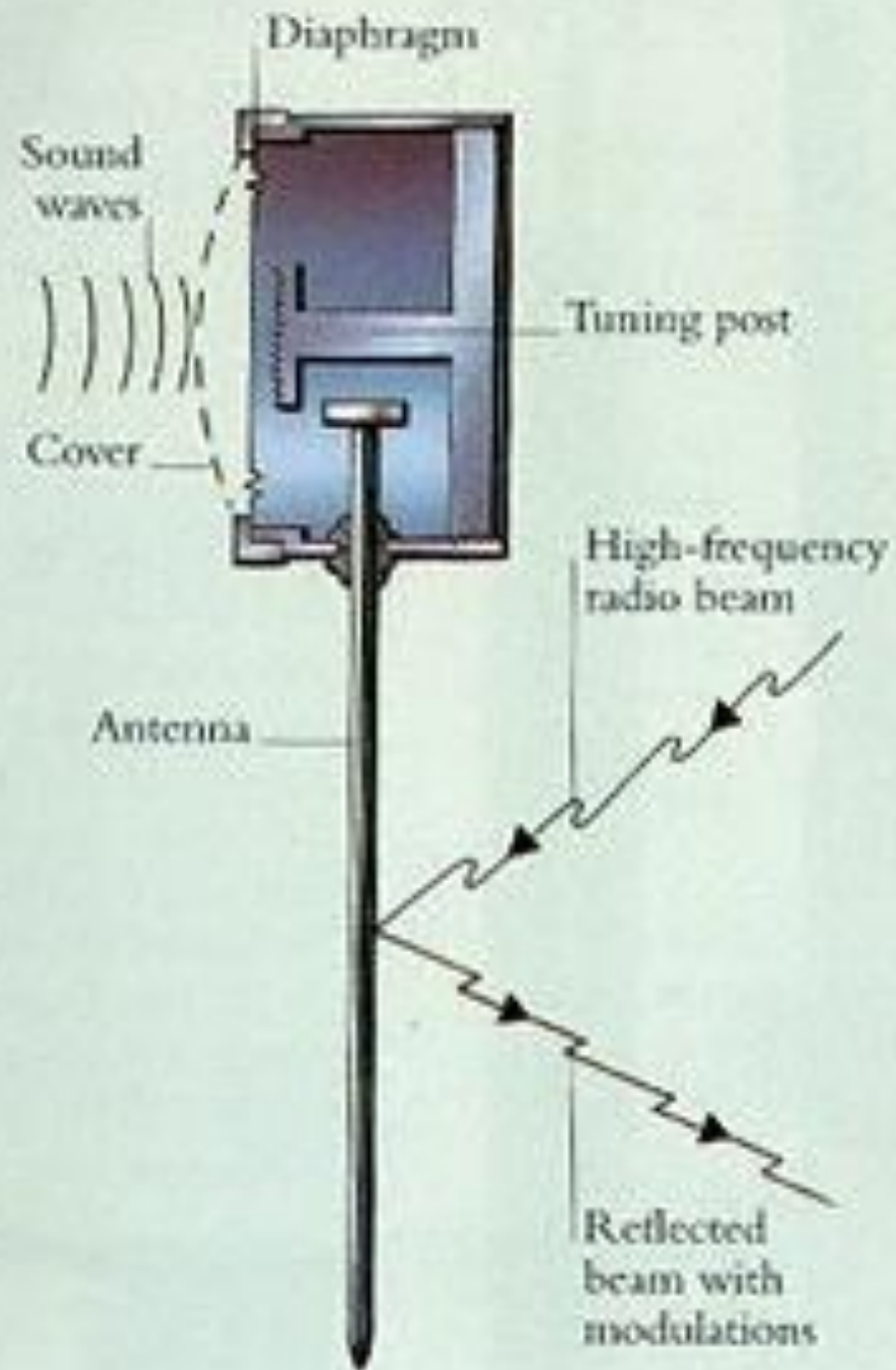

Electromechanical system realized from a MEMS capacitor in a resonant circuit

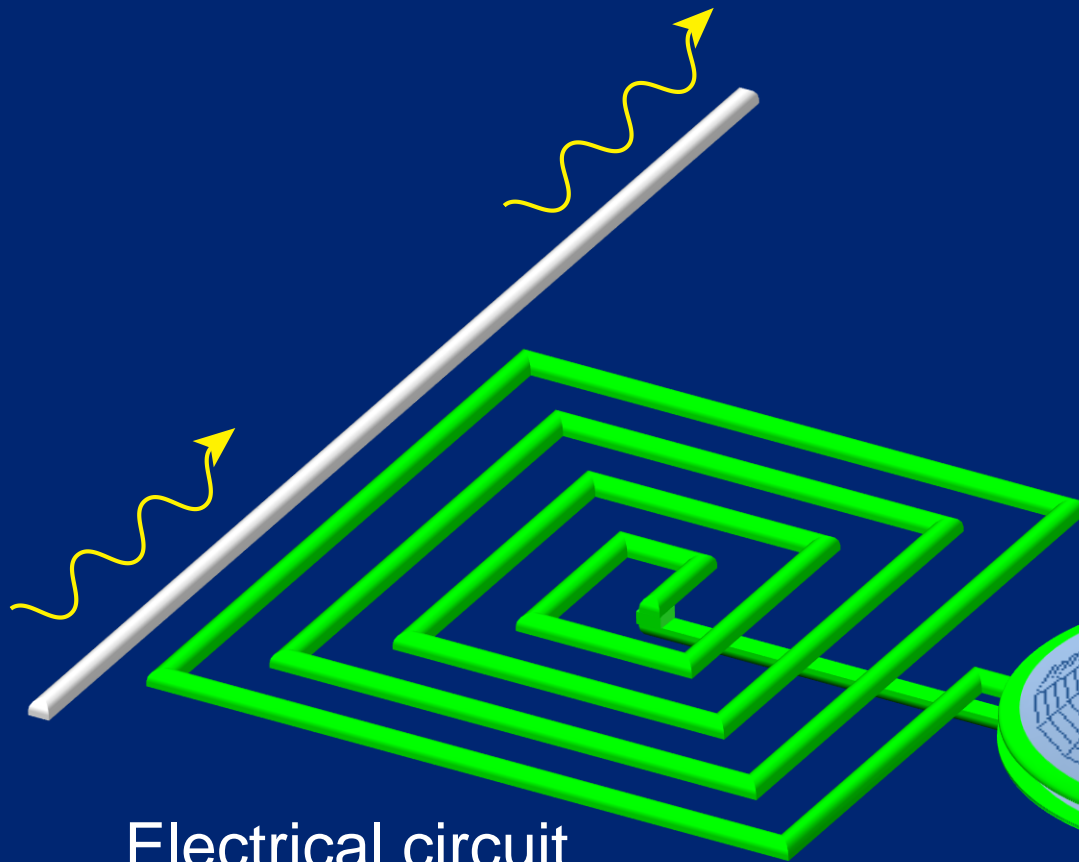

Electrical circuit
resonant at 7.5 GHz

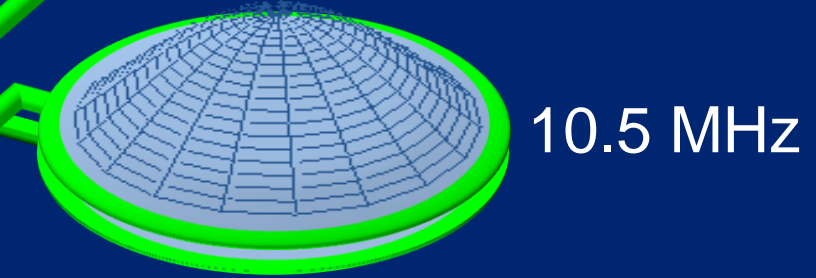
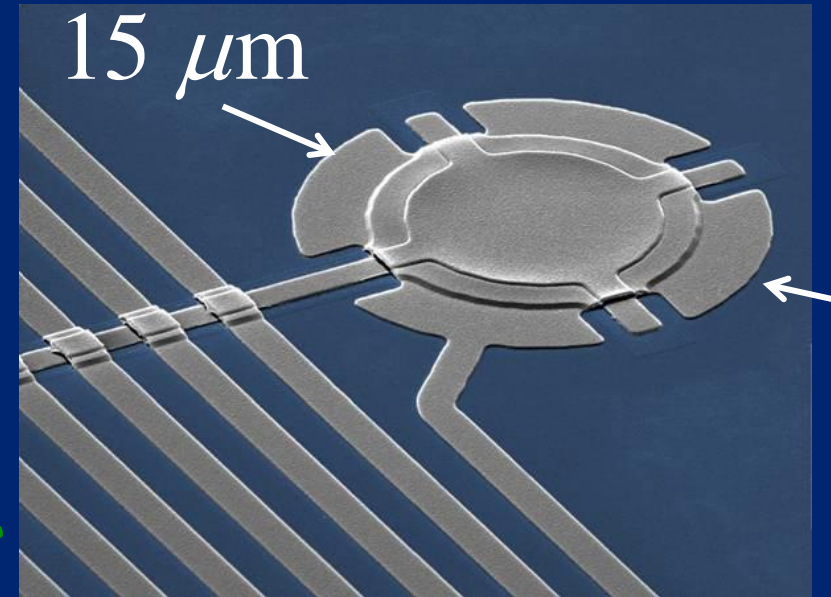

10.5 MHz

capacitor built with suspended
micromechanical drumhead*

*K. Cicak, et al APL **96**, 093502 (2010)

*J. D. Teufel, R. W. Simmonds et al., Nature **471**, 204208 (2011).

Resonant circuit enhances coupling between microwave fields and mechanical motion

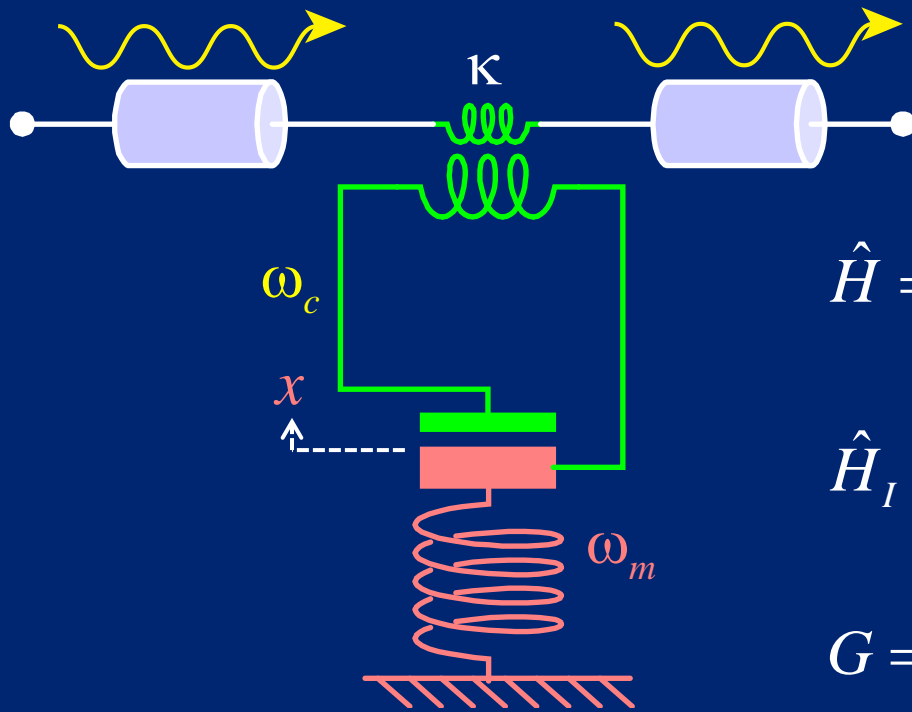

$$\hat{H} = \hbar\omega_c \left(a^\dagger a + \frac{1}{2} \right) + \hbar\omega_m \left(b^\dagger b + \frac{1}{2} \right) + \hat{H}_I$$

$$\hat{H}_I = \hat{F} \cdot \hat{x} = \hbar G a^\dagger a (b^\dagger + b)$$

$$G = \frac{\partial \omega_c}{\partial x} x_{\text{zpf}}$$

κ decay rate of circuit energy

Detuned microwave drive couples mechanical motion to electrical circuit resonance

$$\hat{H}_I = \hbar G a^\dagger a (b^\dagger + b) \quad \text{excite circuit at } \omega_d = \omega_c - \omega_m$$

$$\hat{H}_I = \hbar G \sqrt{N_d} (ab^\dagger + a^\dagger b) \quad \text{linearized interaction} \quad \Gamma = \frac{4N_d G^2}{\kappa}$$

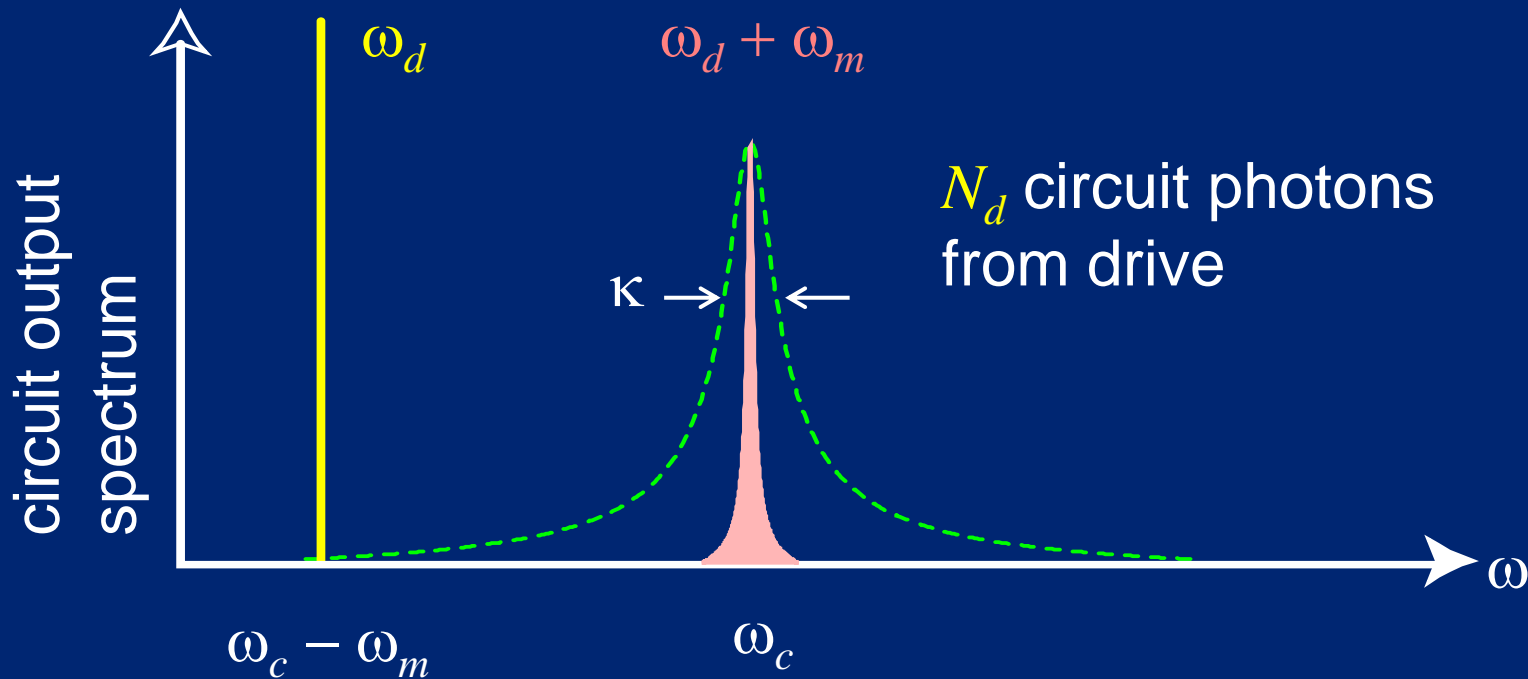

Electrically detect thermal motion of drumhead

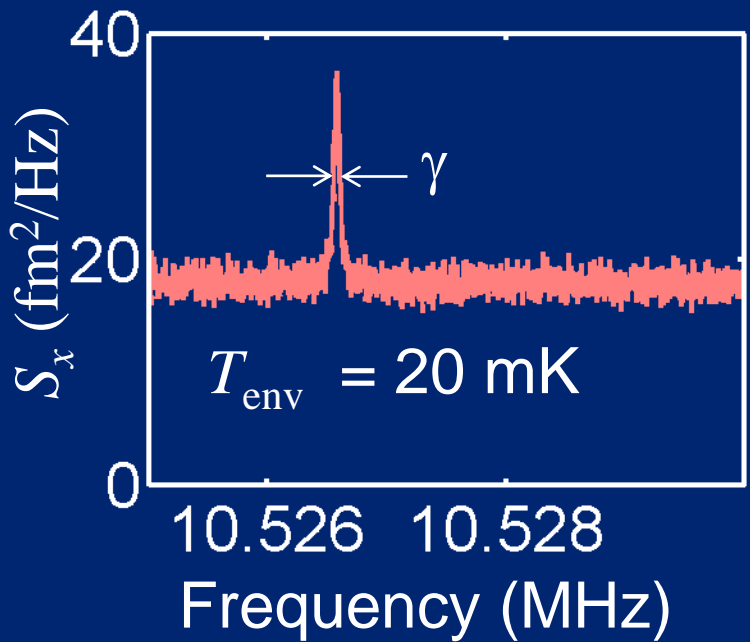
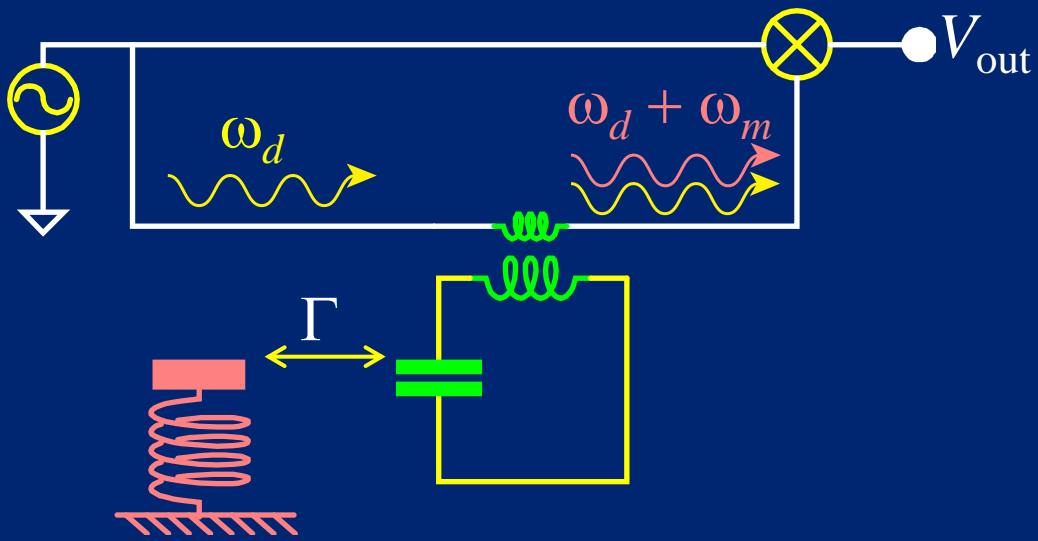

$$\omega_c = 2\pi \times 7.5 \text{ GHz}$$

$$\kappa = 2\pi \times 200 \text{ kHz}$$

$$\omega_m = 2\pi \times 10.5 \text{ MHz}$$

$$\gamma = 2\pi \times 30 \text{ Hz}$$

$$x_{zpf} = 4.1 \text{ fm}$$

J. D. Teufel, J. W. Harlow, C. A. Regal, KWL, Phys. Rev. Lett., 101, 197203 (2008).

J. D. Teufel, T. Donner, KWL, R. W. Simmonds, et al Nature, 475, 359–363 (2011).

Mechanical motion in equilibrium with cryostat

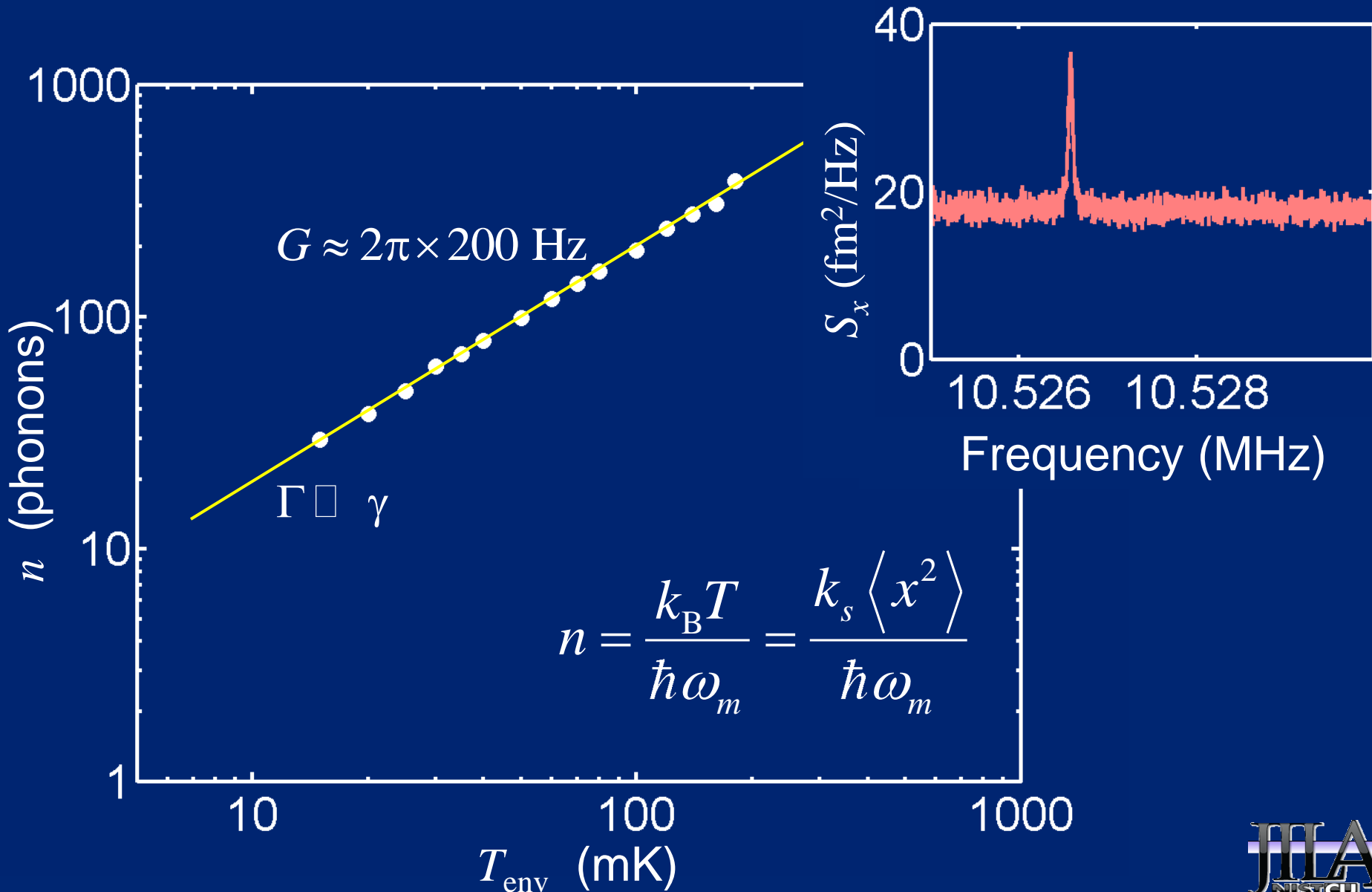

Measurement cools mechanical motion below single phonon occupancy

$$\hat{H}_I = \hbar G \sqrt{N_d} (ab^\dagger + a^\dagger b)$$

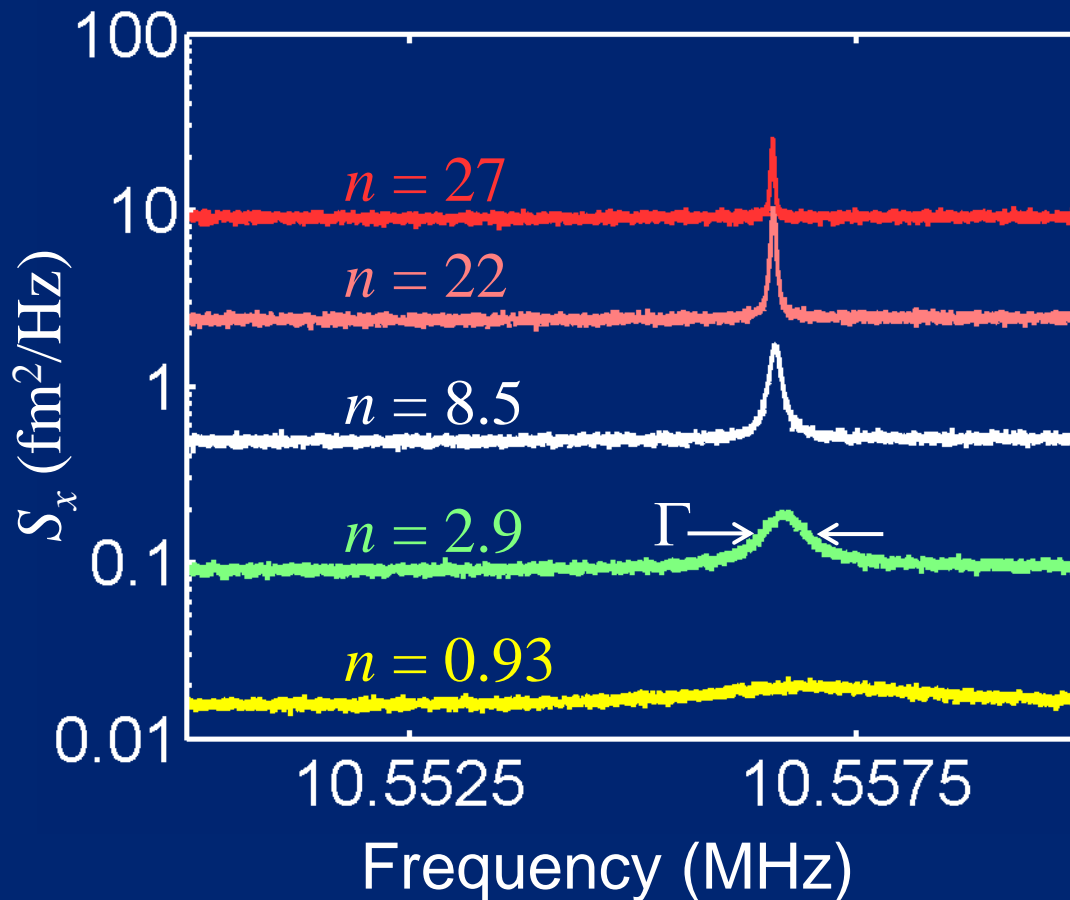

$$\Gamma = \frac{4N_d G^2}{\kappa}$$

N_d

Increasing strength
of measurement
and cooling

Many-photon cooperativity > 1 accesses the quantum regime

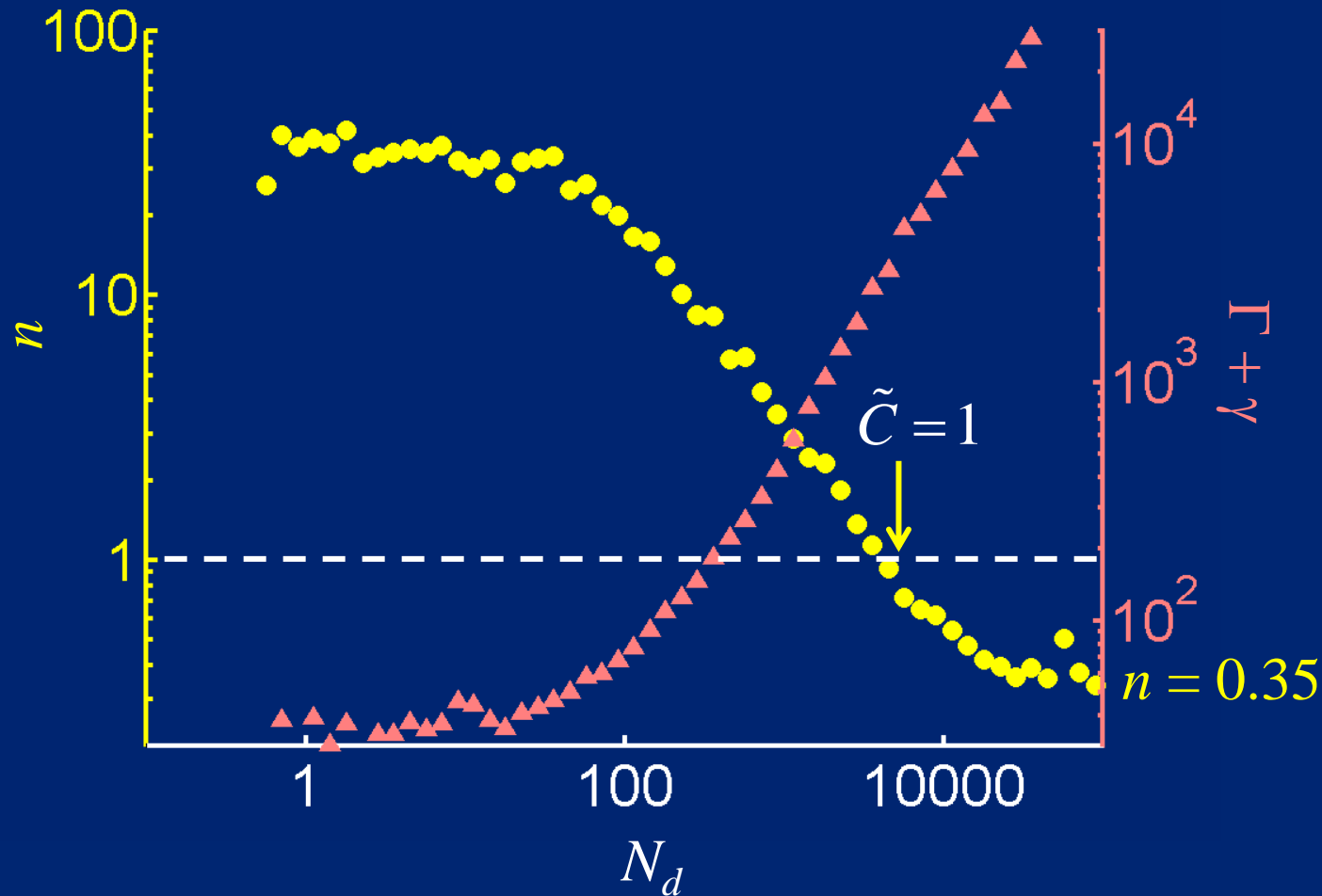

cooperativity

$$\tilde{C} = \frac{4N_d G^2}{(n_{\text{env}} \gamma) \kappa}$$

State transfer between mechanics
and itinerant microwave fields

Can mechanical oscillators form quantum coherent memories for itinerant microwaves?

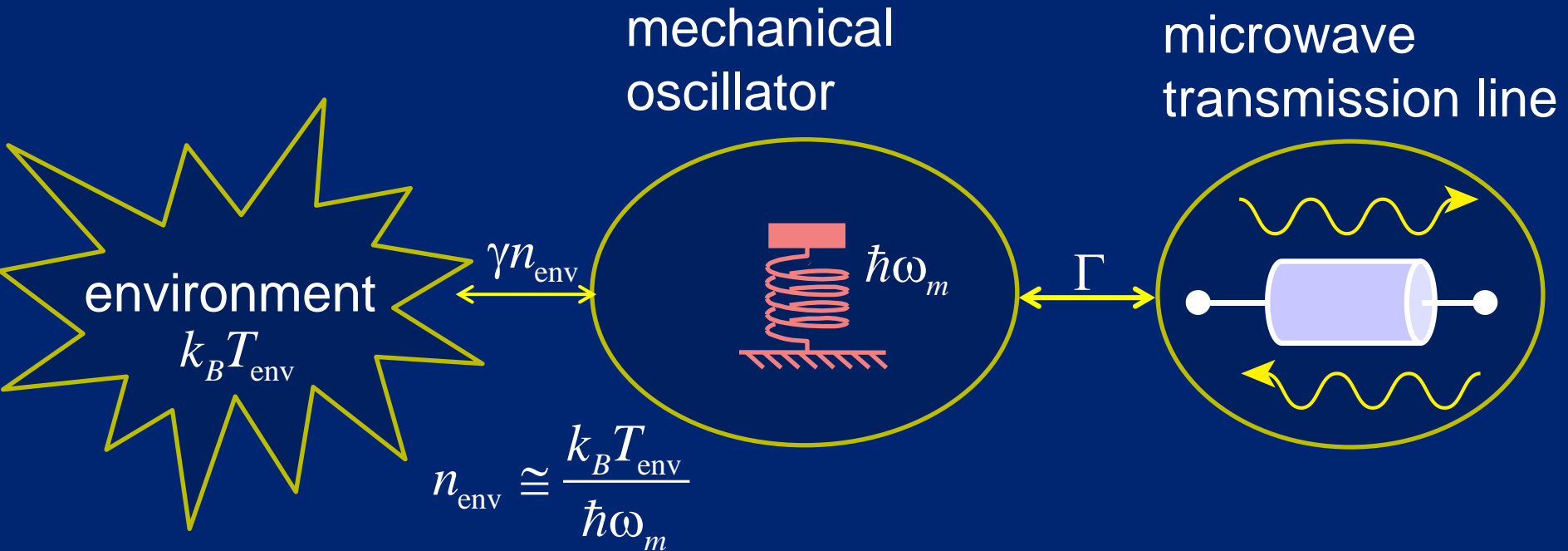

catch, store, and release propagating microwaves

mechanical oscillators

long-lived coherence $T_2 > 300 \mu\text{s}$

compact

integrable with superconducting qubits

Large cooperativity enables quantum control of mechanics with microwaves

$$\hat{H}_I(t) = \hbar G \sqrt{N_d(t)} (ab^\dagger + a^\dagger b) \quad \Gamma(t) = \frac{4G^2 N_d(t)}{\kappa}$$

$n_{\text{env}} \gamma < \Gamma < \kappa$ state transfer between mechanics and itinerant microwave fields

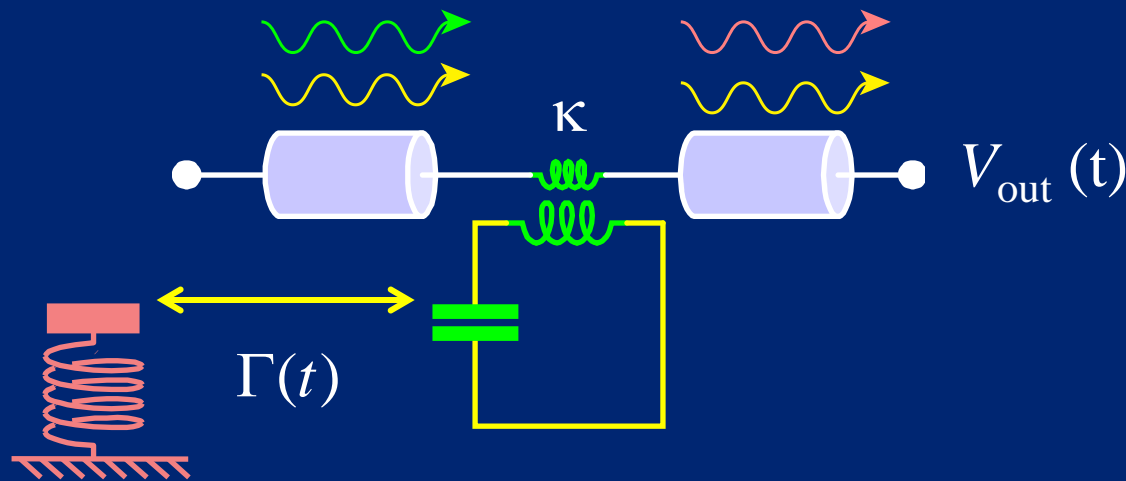

Extreme resolved sideband limit enables agile state control

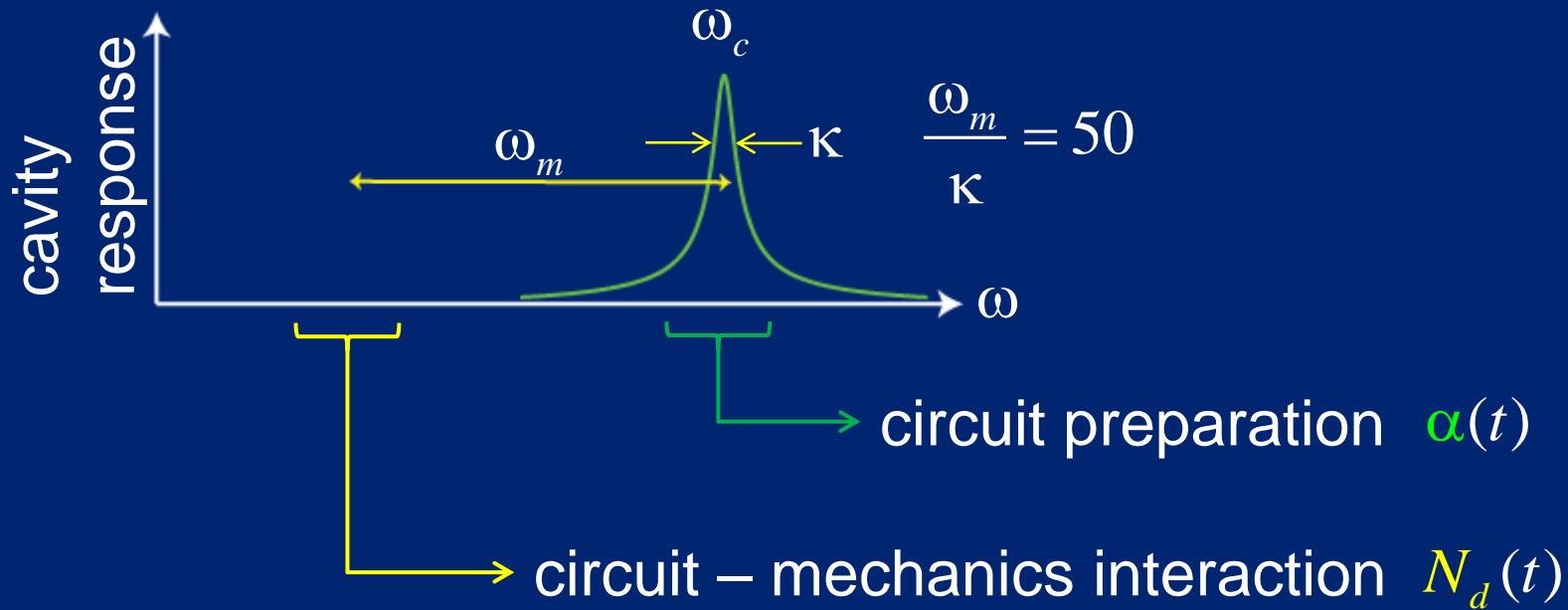

$$\hat{H}_I = \hbar G \sqrt{N_d(t)} (ab^\dagger + a^\dagger b)$$

Measure oscillator via state transfer to itinerant microwave fields

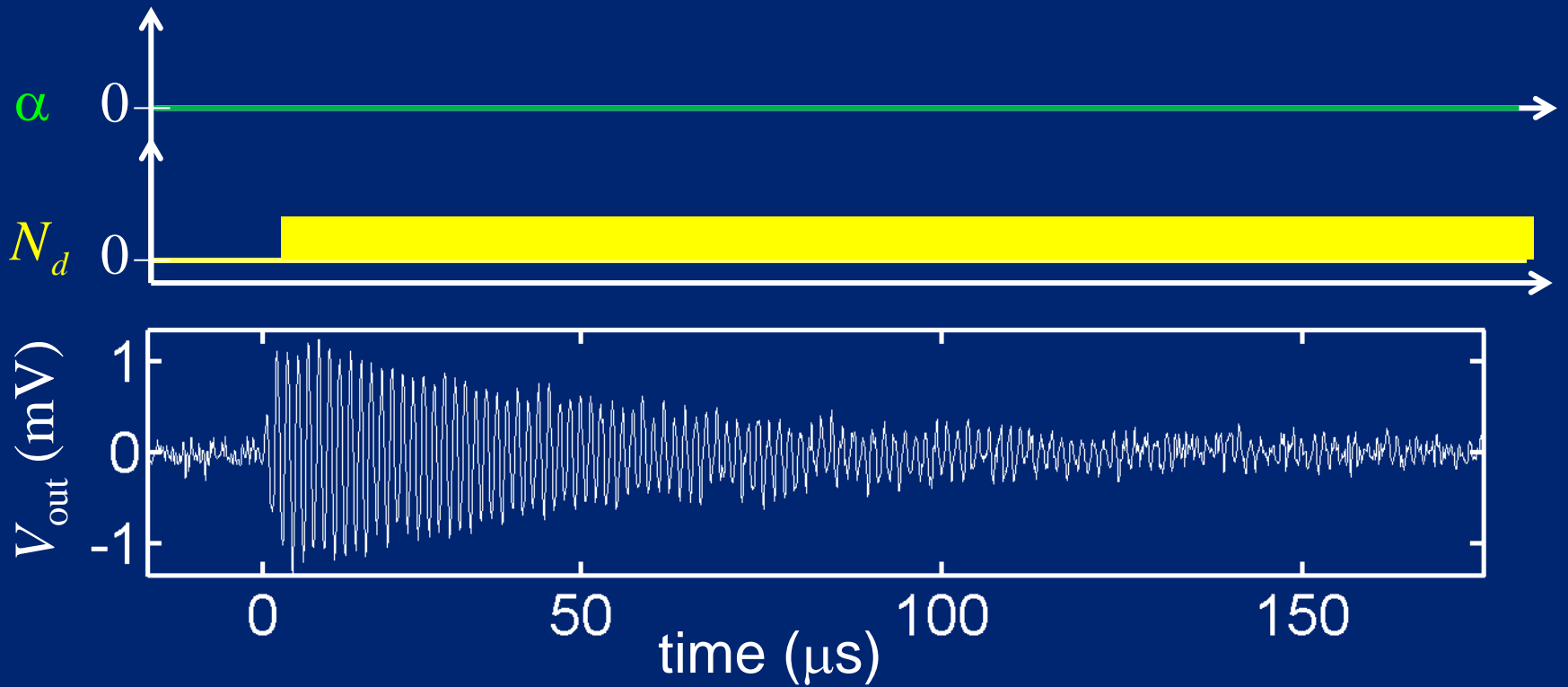

Measure oscillator via state transfer to itinerant microwave fields

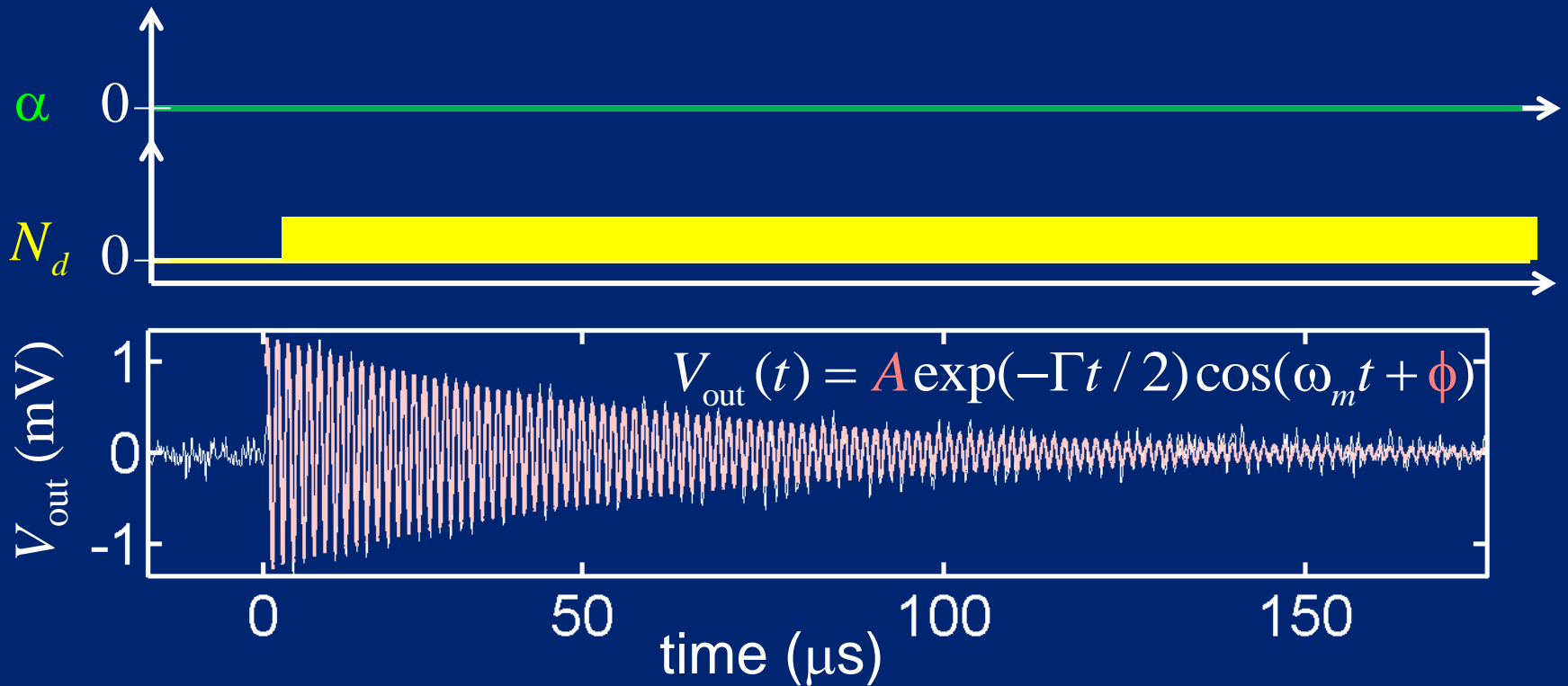

optimally filter to find quadrature amplitudes

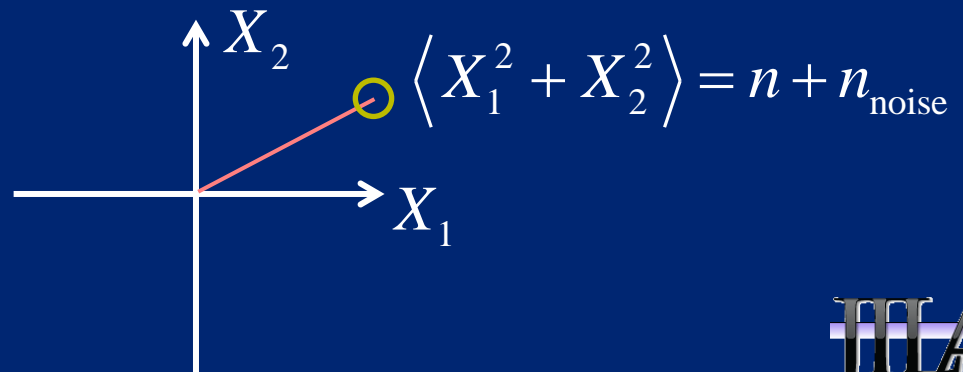

Thermal state of oscillator reconstructed by repeated measurements

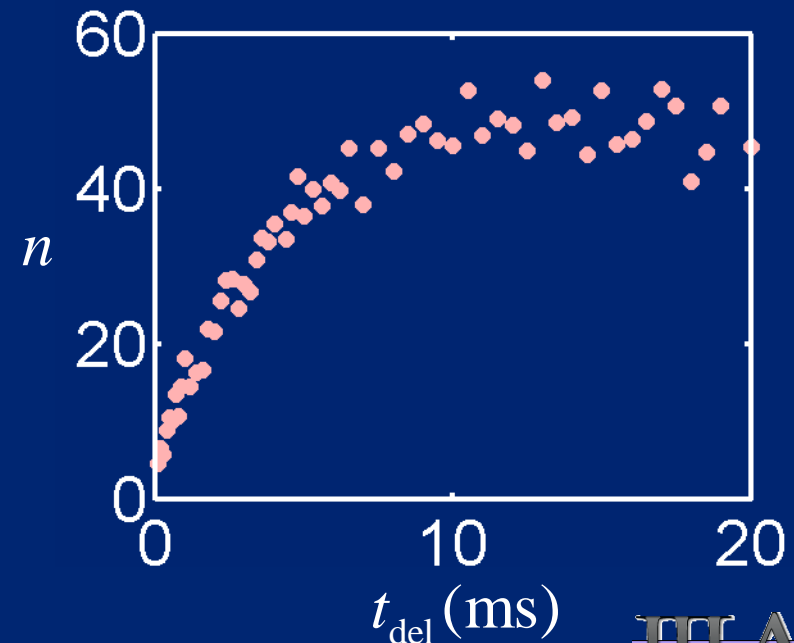
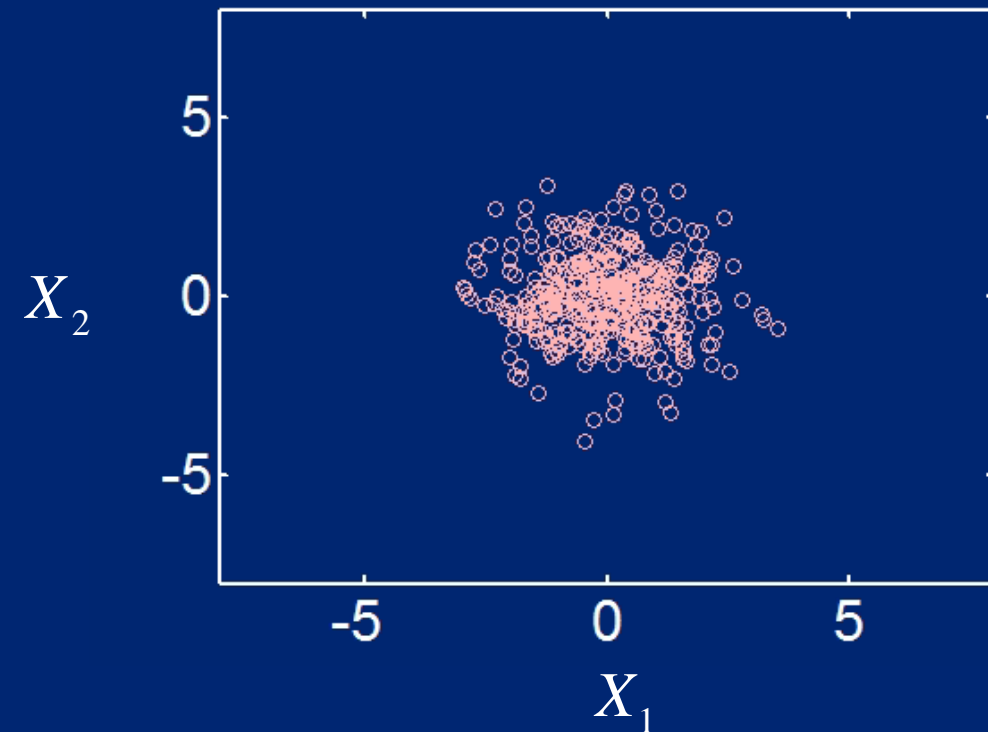
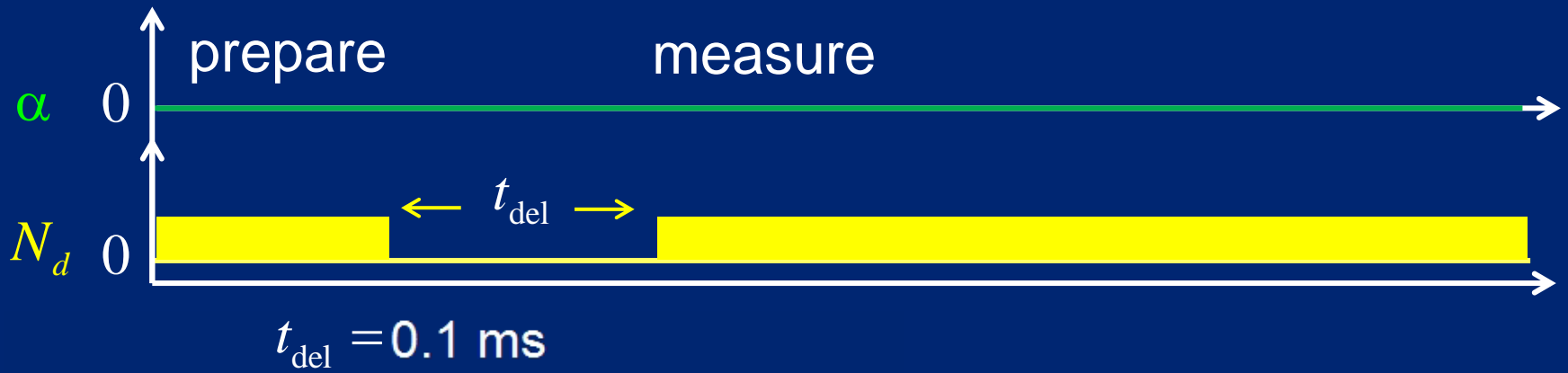

Mechanical oscillator is a long-lived coherent memory for microwaves

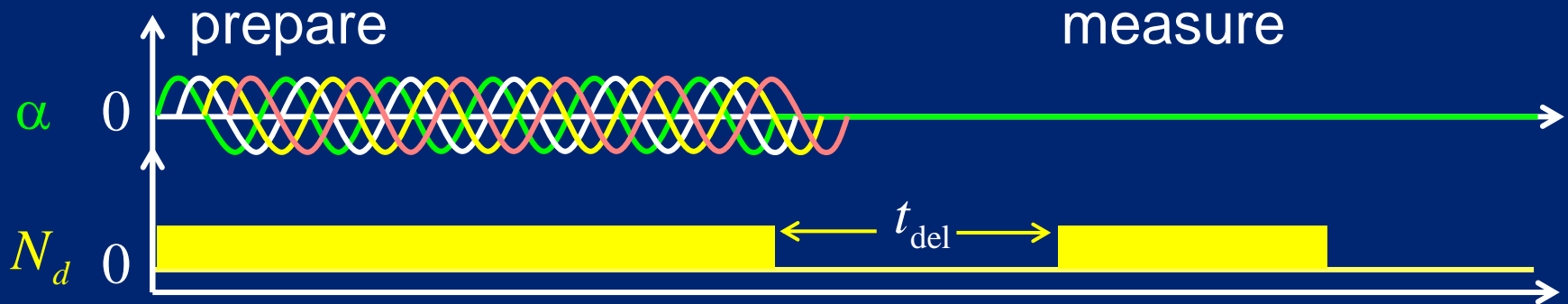

$t_{\text{del}} = 200 \mu\text{s}$

$t_{\text{del}} = 20 \text{ ms}$

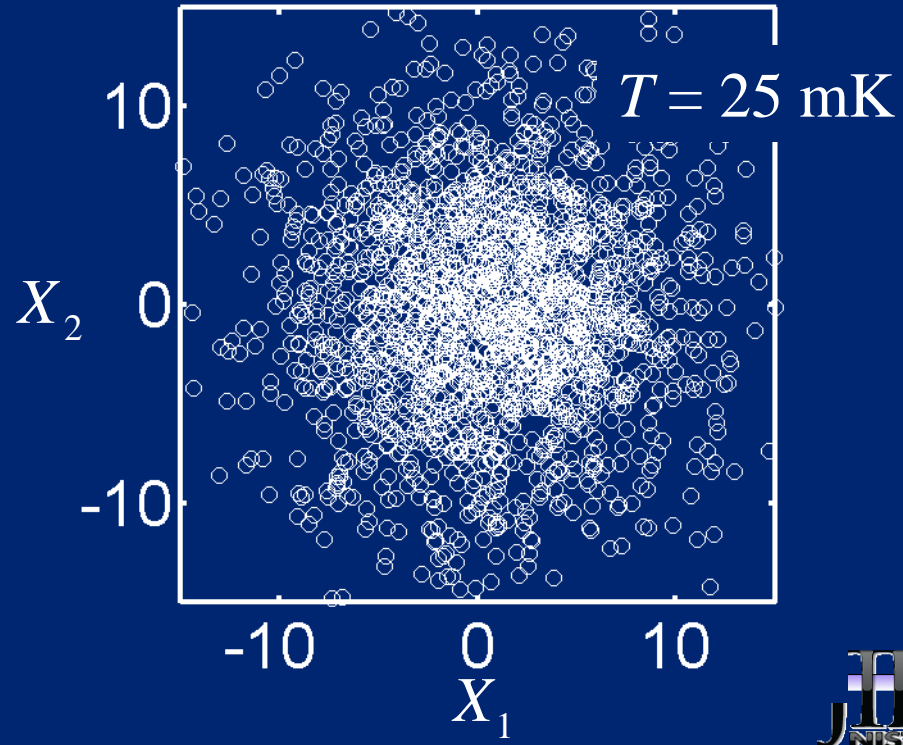
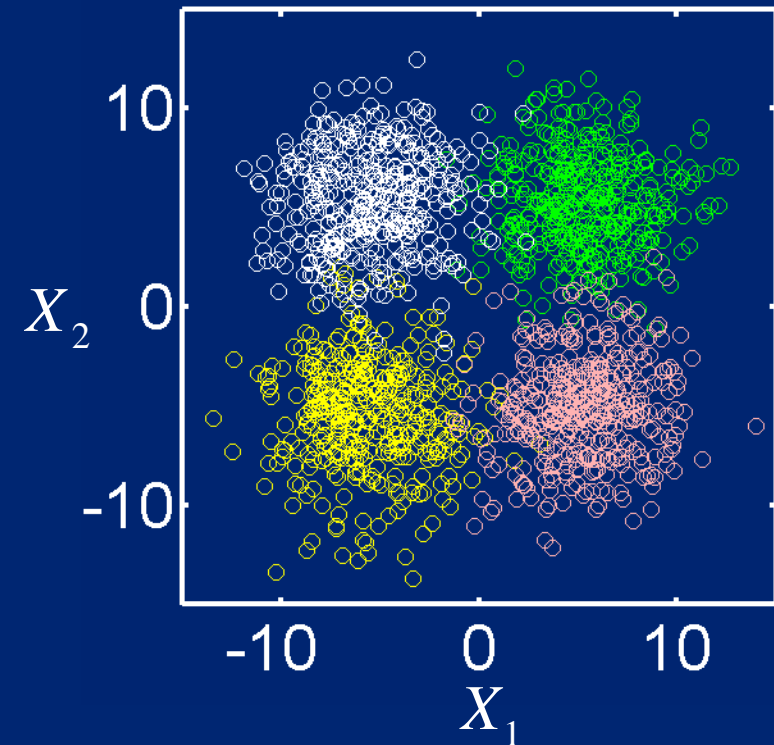

State transfer prepares mechanical oscillator in a low entropy state

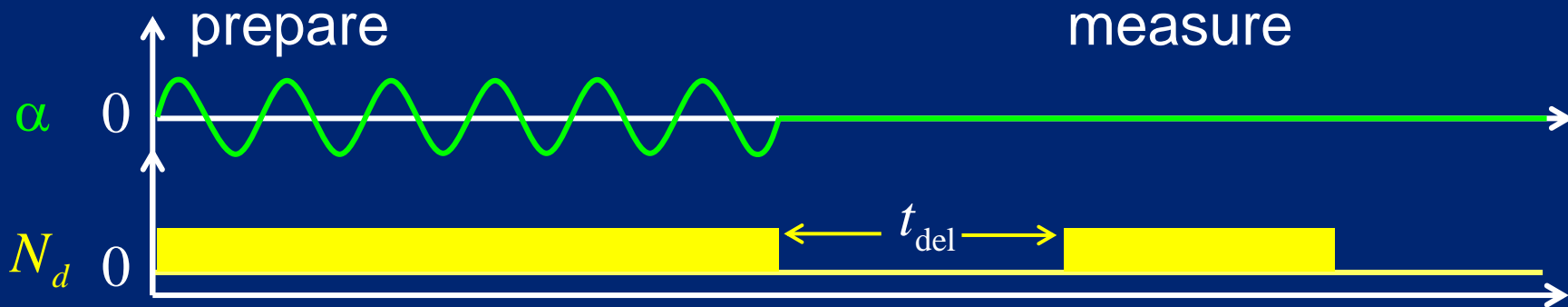

$$n_{\text{coh}} = \langle \frac{X_1^2}{2} \rangle \langle \frac{X_2^2}{2} \rangle \langle n_{\text{noise}} \rangle^2$$

$$n_{\text{therm}} = \langle \Delta X_1^2 \rangle + \langle \Delta X_2^2 \rangle - n_{\text{noise}}$$

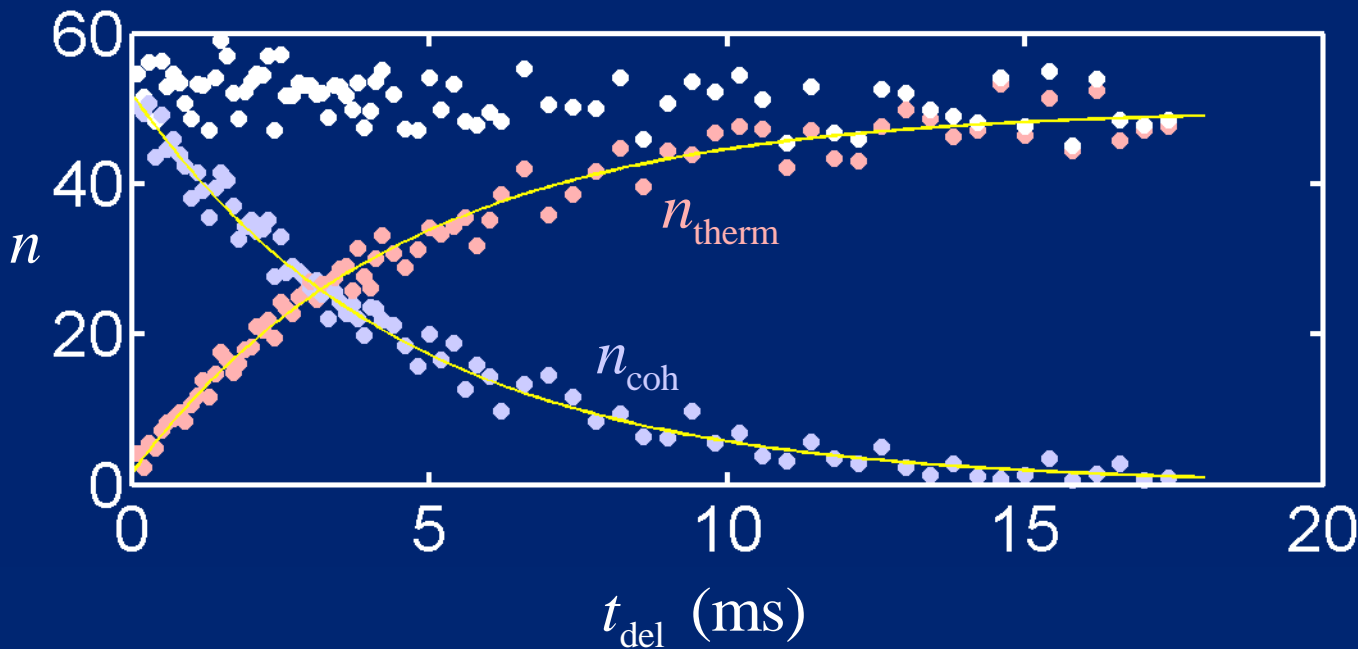

State transfer between mechanical
oscillator and microwave circuit

Strong coupling regime enables state transfer between circuit and mechanical oscillator

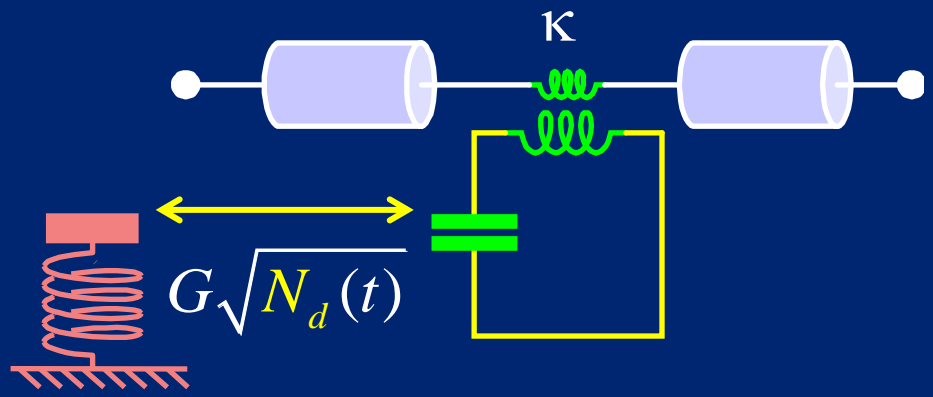

$$G\sqrt{N_d} > \kappa, n_{\text{therm}}\gamma$$

state transfer between mechanics and LC circuit

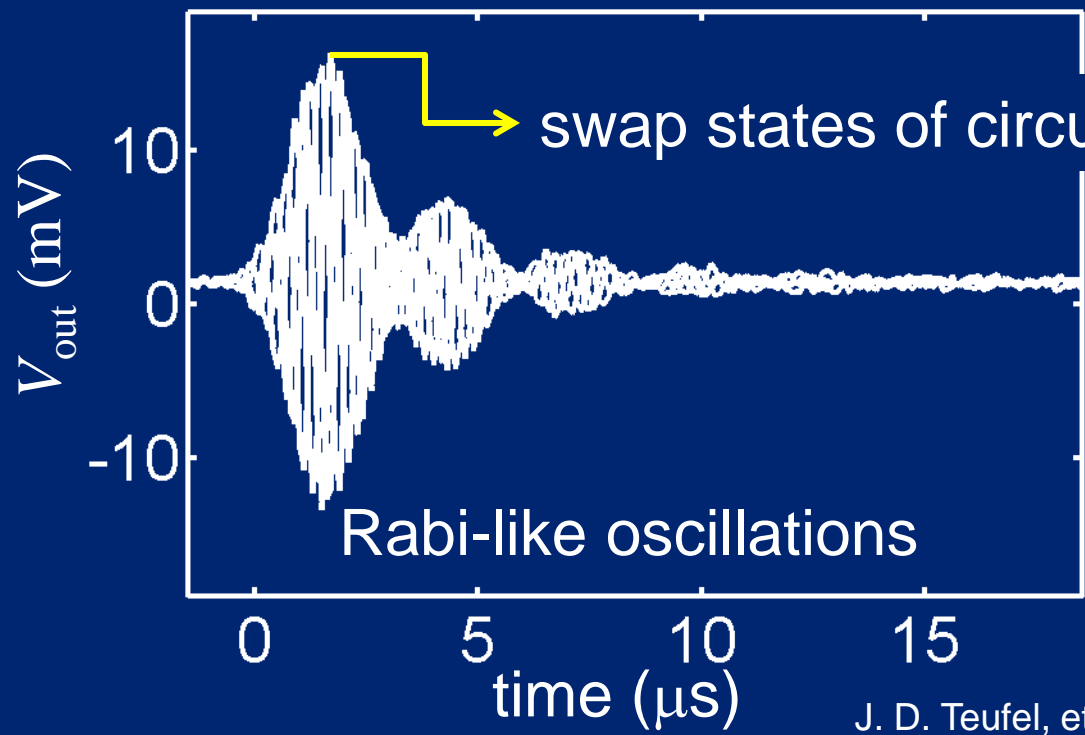

Mechanical oscillator stores state much longer than resonant circuit

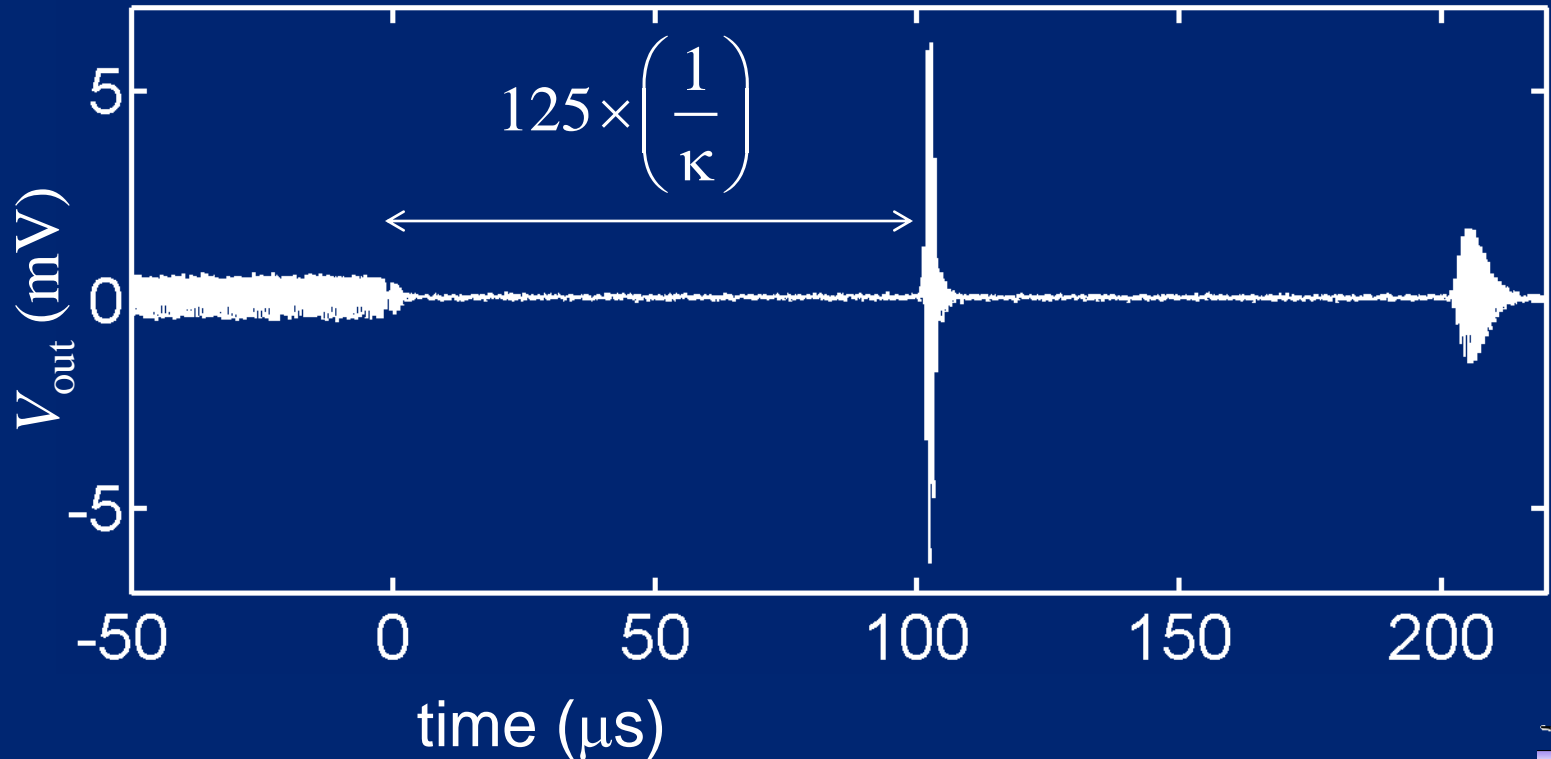
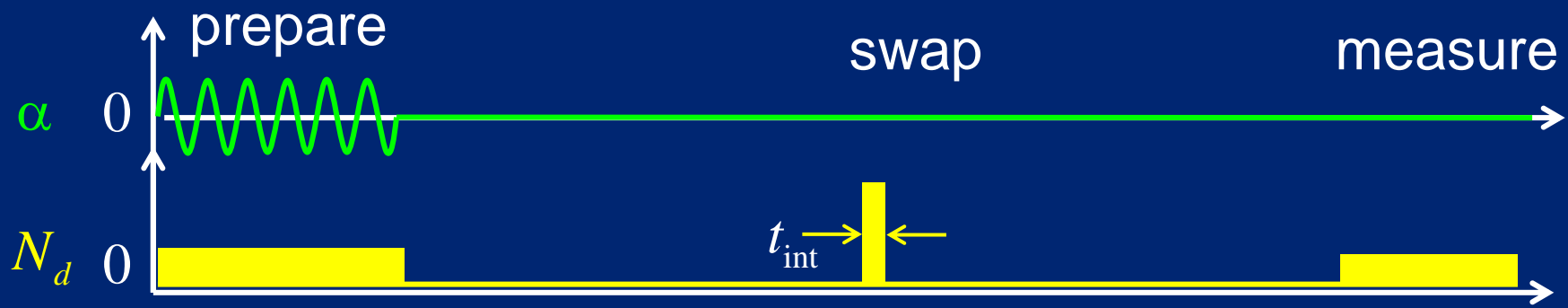

Mechanical oscillator stores state much longer than resonant circuit

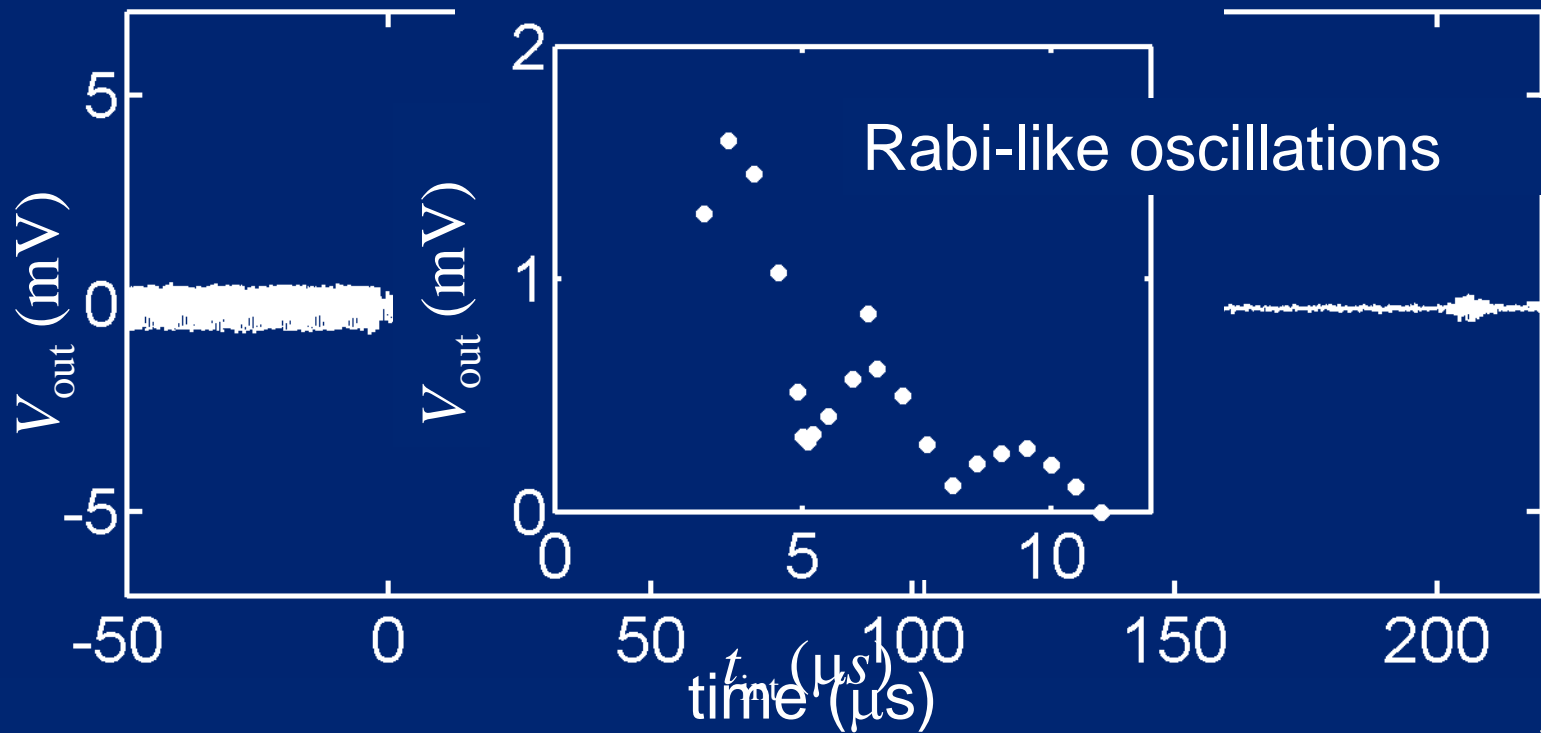
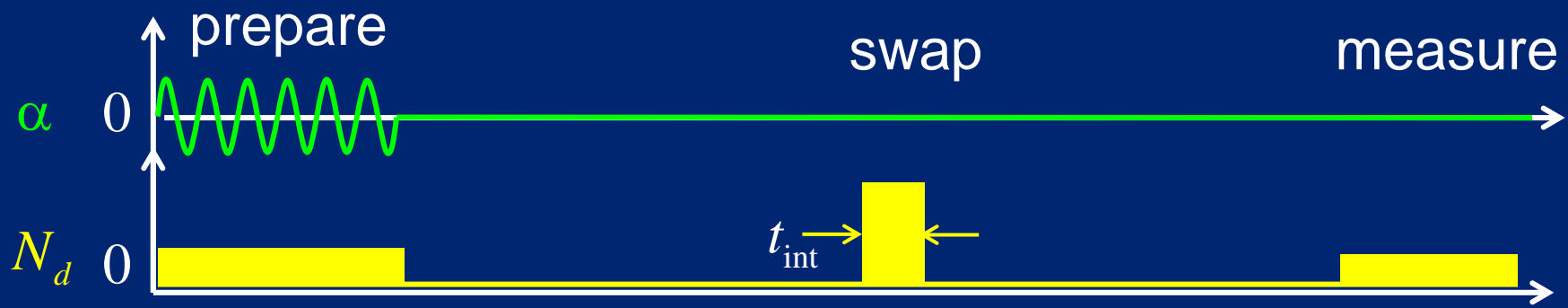

A quantum interface between electricity and light



with Cindy Regal
and Ray Simmonds

Microwave to optical quantum state transfer

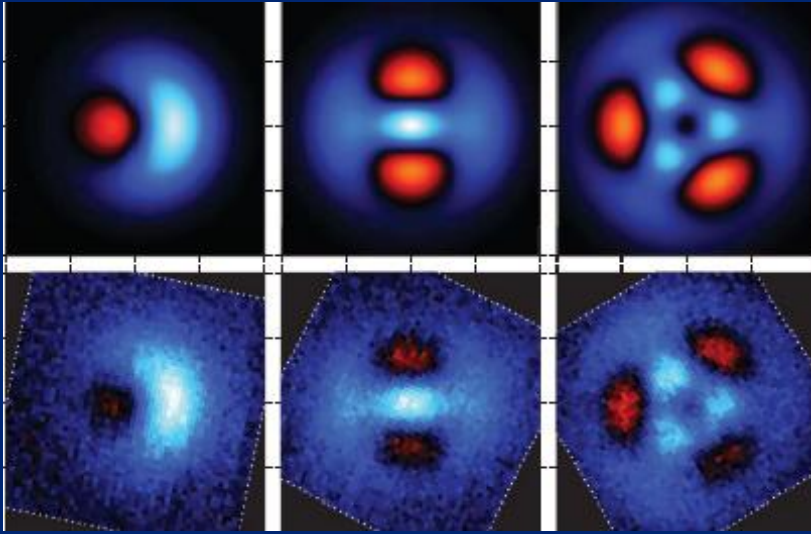

Hofheinz...Martinis, Cleland, Nature (2009)

Microwaves:

Arbitrary quantum states

Require ultralow temperatures

Optics:

Communication and storage



Mechanical oscillators couple to both light and electricity in a quantum regime

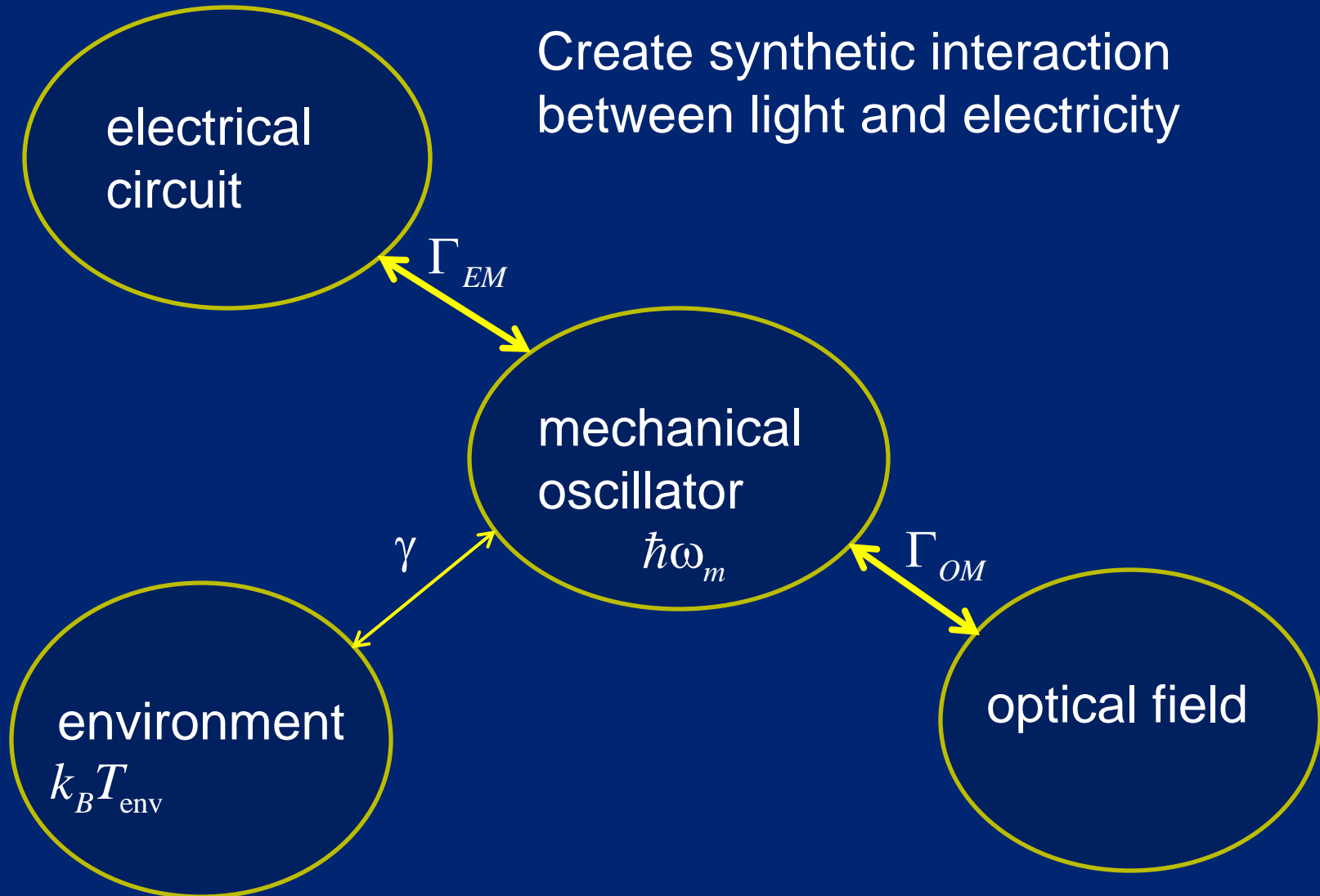

Couple microwave to optics through one mechanical oscillator

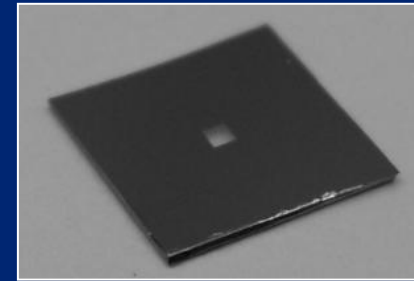
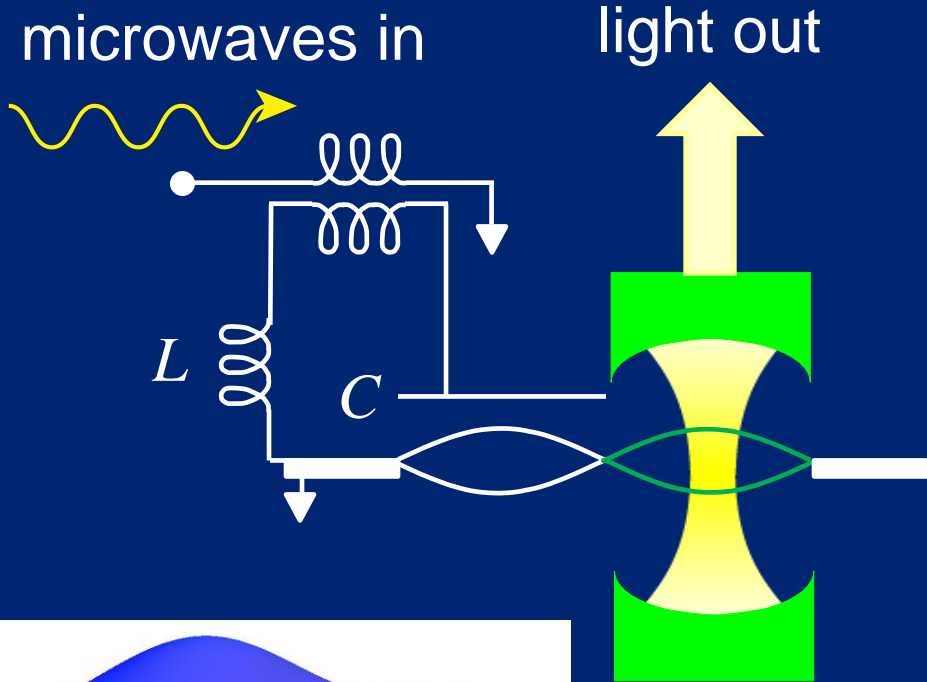

Si_3N_4 membrane

(1,1)

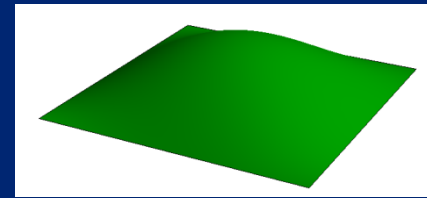

(2,2)

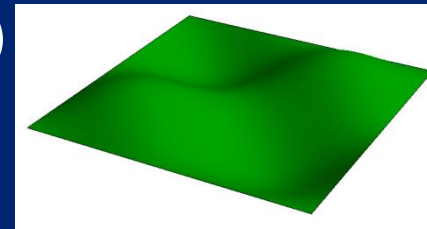

Membrane in free-space cavity
Superconducting LC circuit

Mechanics and optics
couple to different antinodes

Assemble optical-electrical-mechanical device by joining two chips

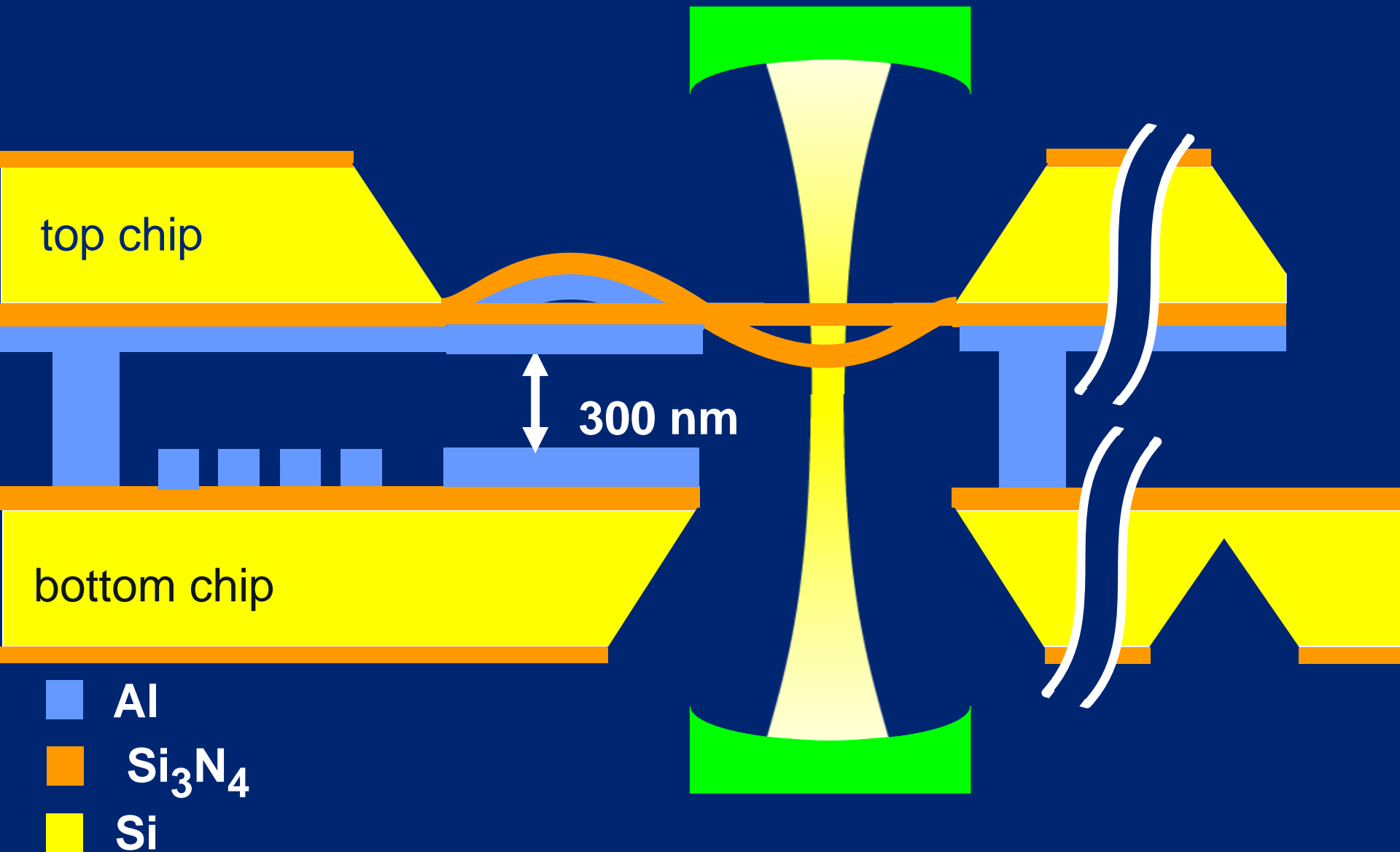

Bottom chip: part of a microwave resonant circuit

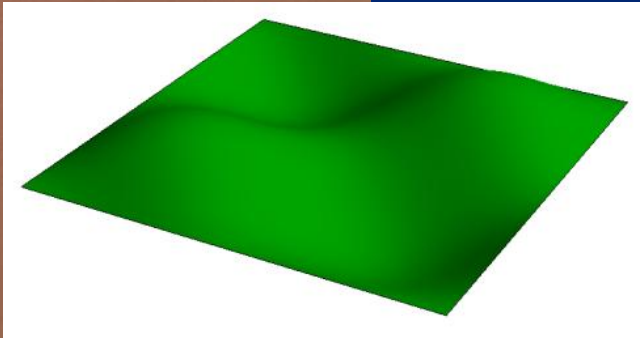
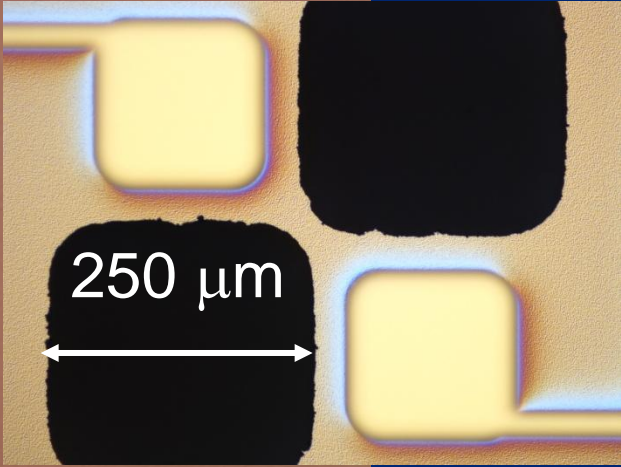
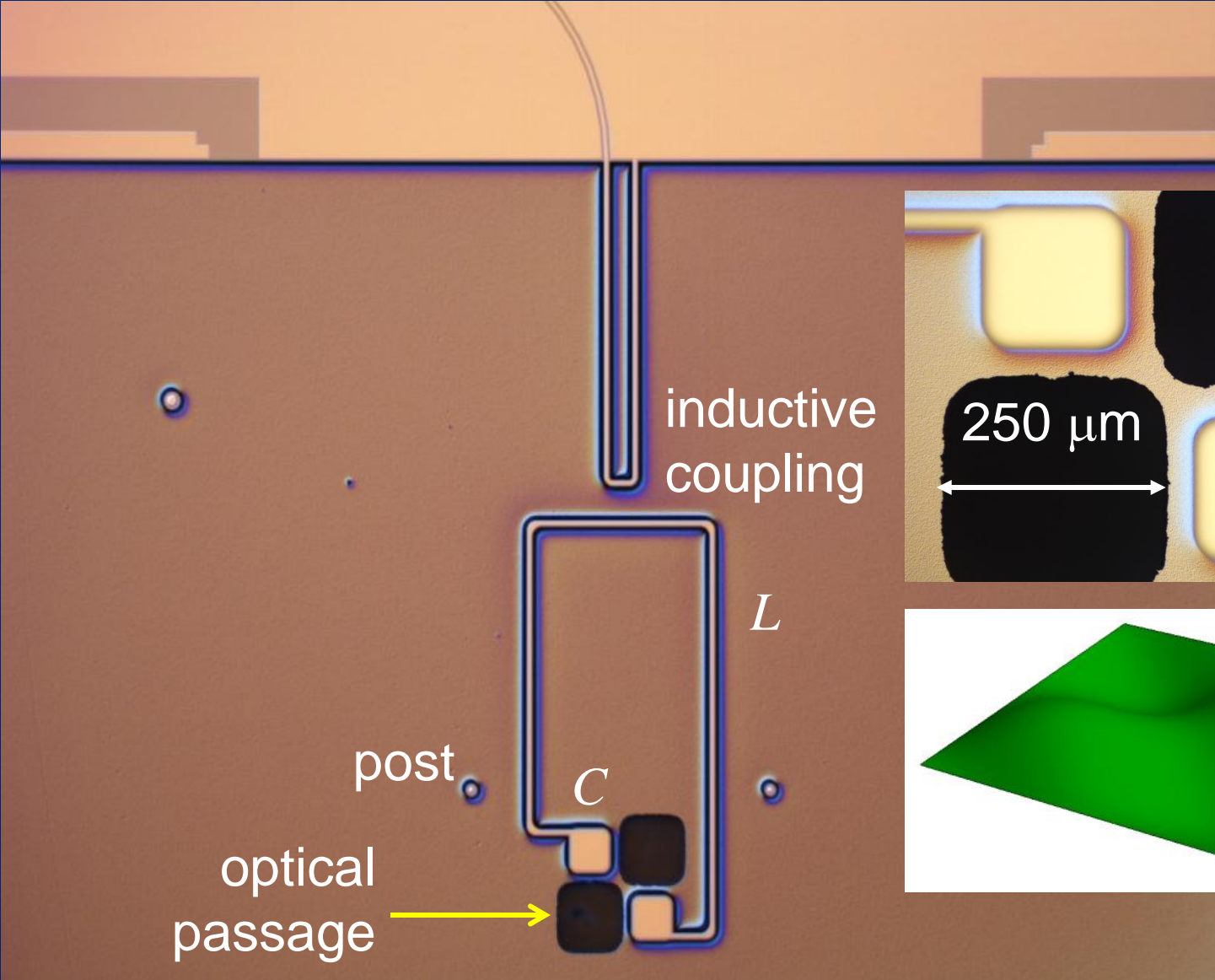

Opto-electromechanical exploits symmetry of 2,2 membrane mode

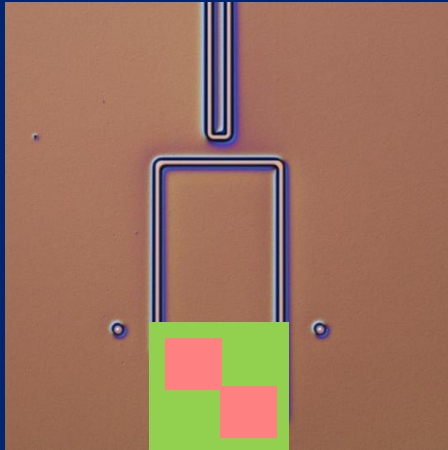

top chip

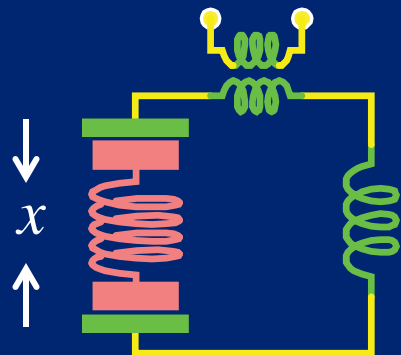
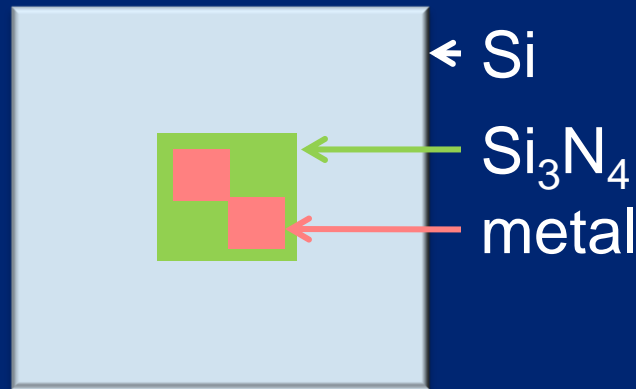

no galvanic connection
between top and bottom chip

Images of bottom and top chips

bottom chip

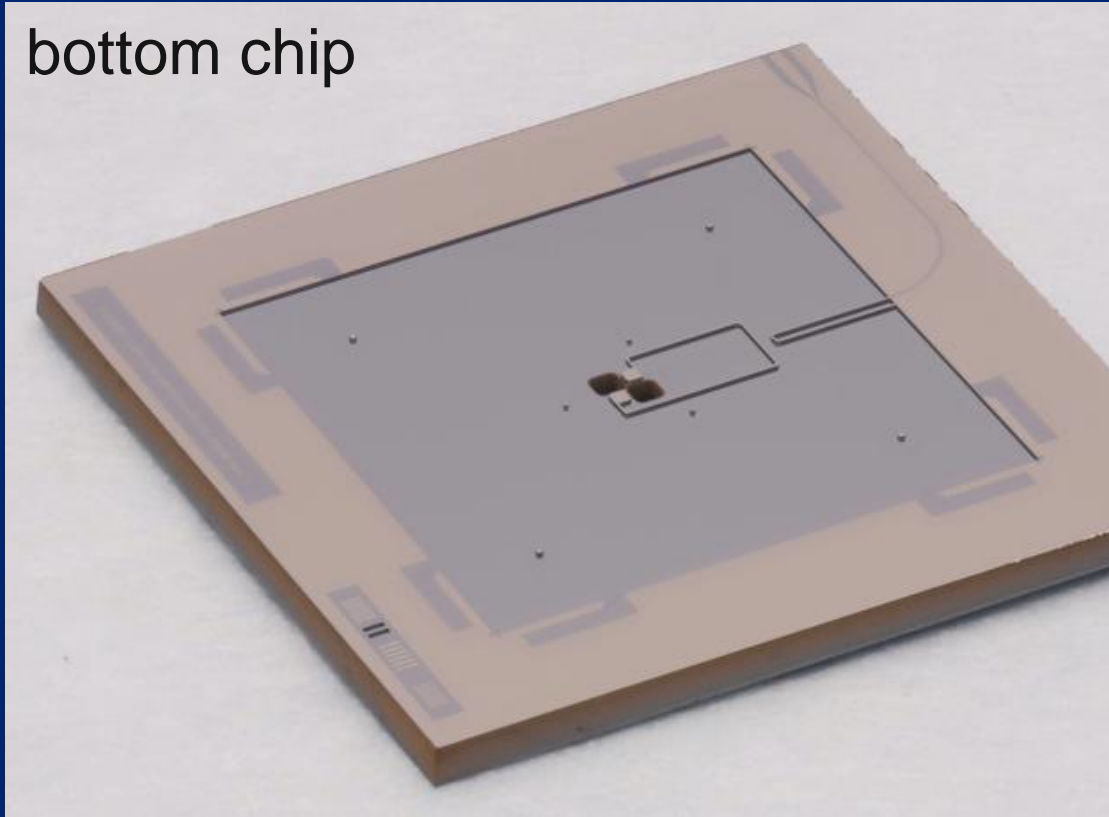

top chip

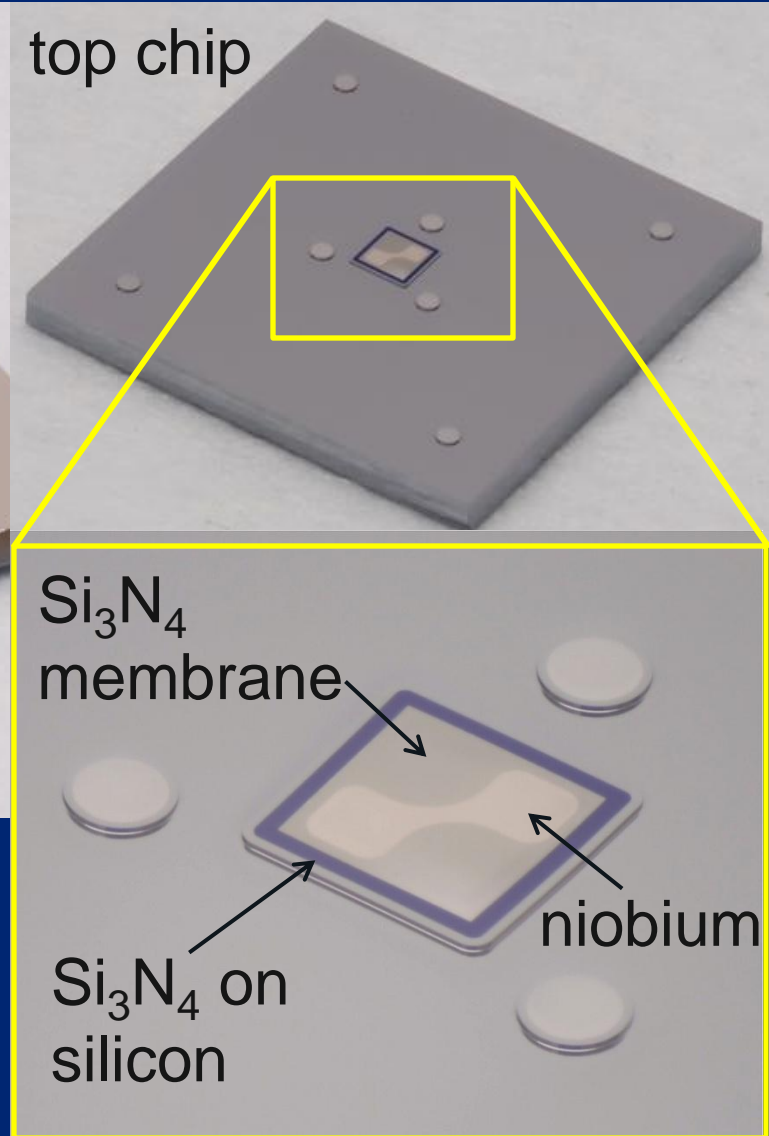

Assembled flip-chip structure

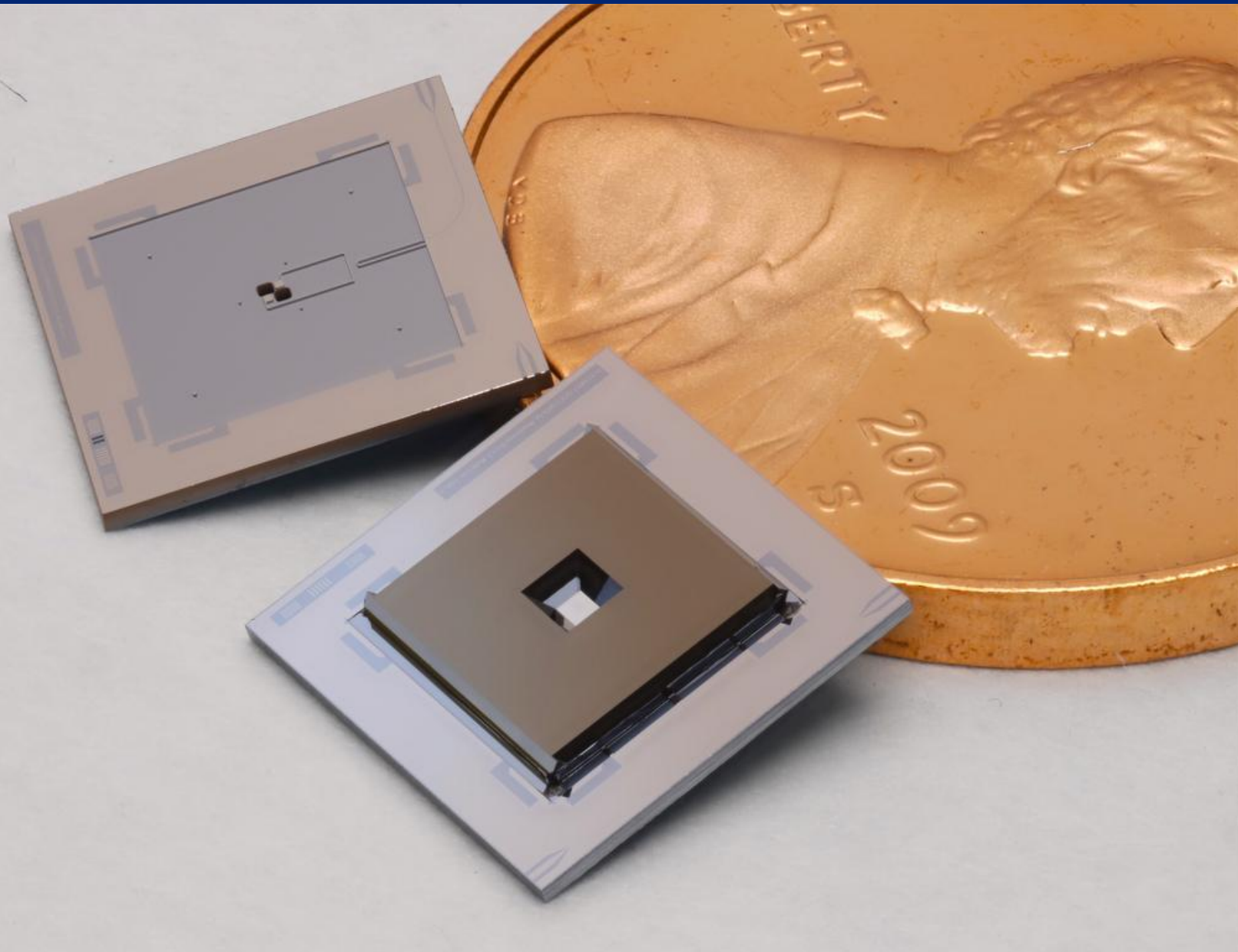

Electromechanics with a Si_3N_4 membrane

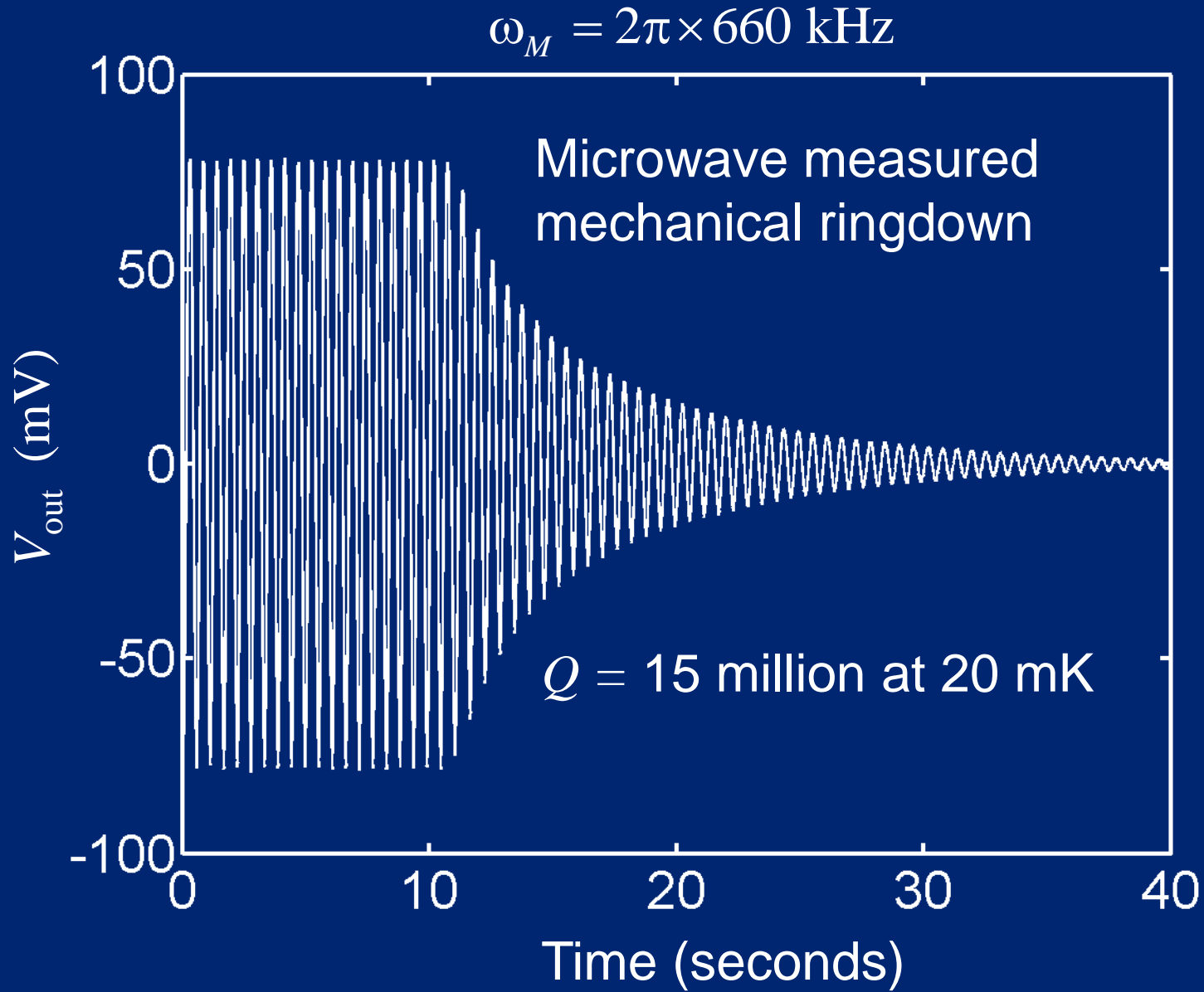

Dielectric membrane in optical cavity*



Regal
group

design of optical cavity coupled to membrane motion

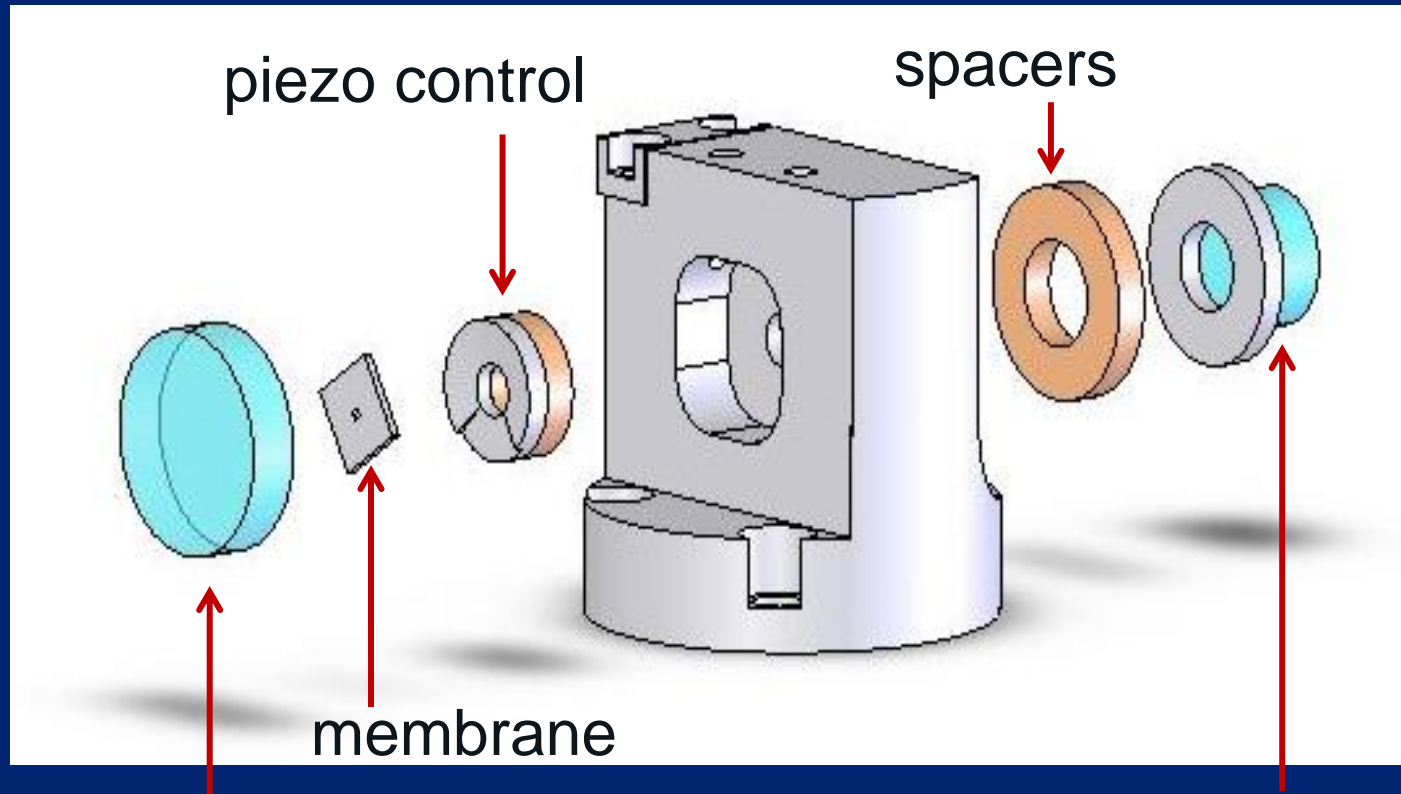

high finesses
end mirror

high finesses
end mirror

“*Membrane in the middle”

J. D. Thompson, J. G. E. Harris, et al Nature 452 72–75 (2008)

Compact, cryogenic optical cavity designed to incorporate opto-electromechanical structures



Regal group

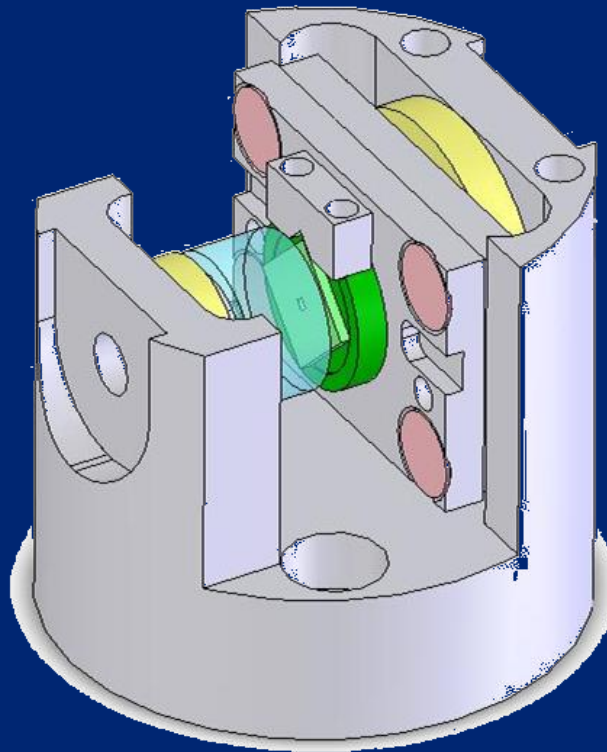

design diagram

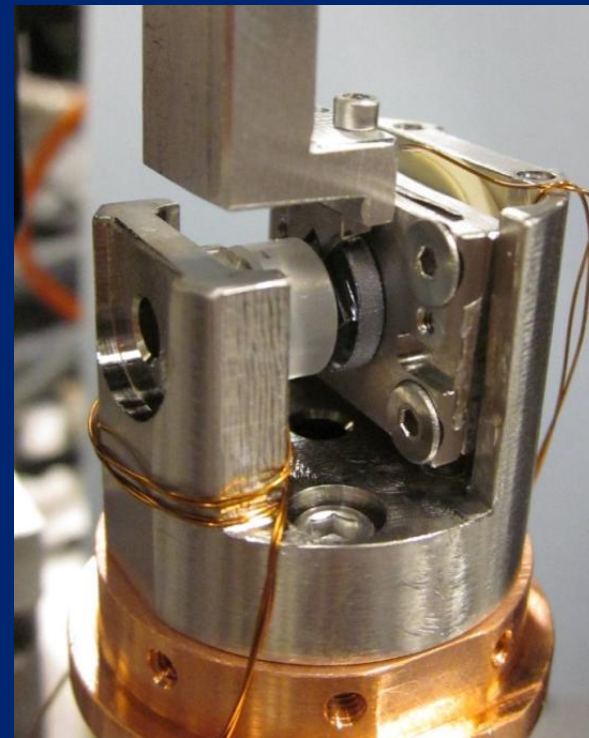
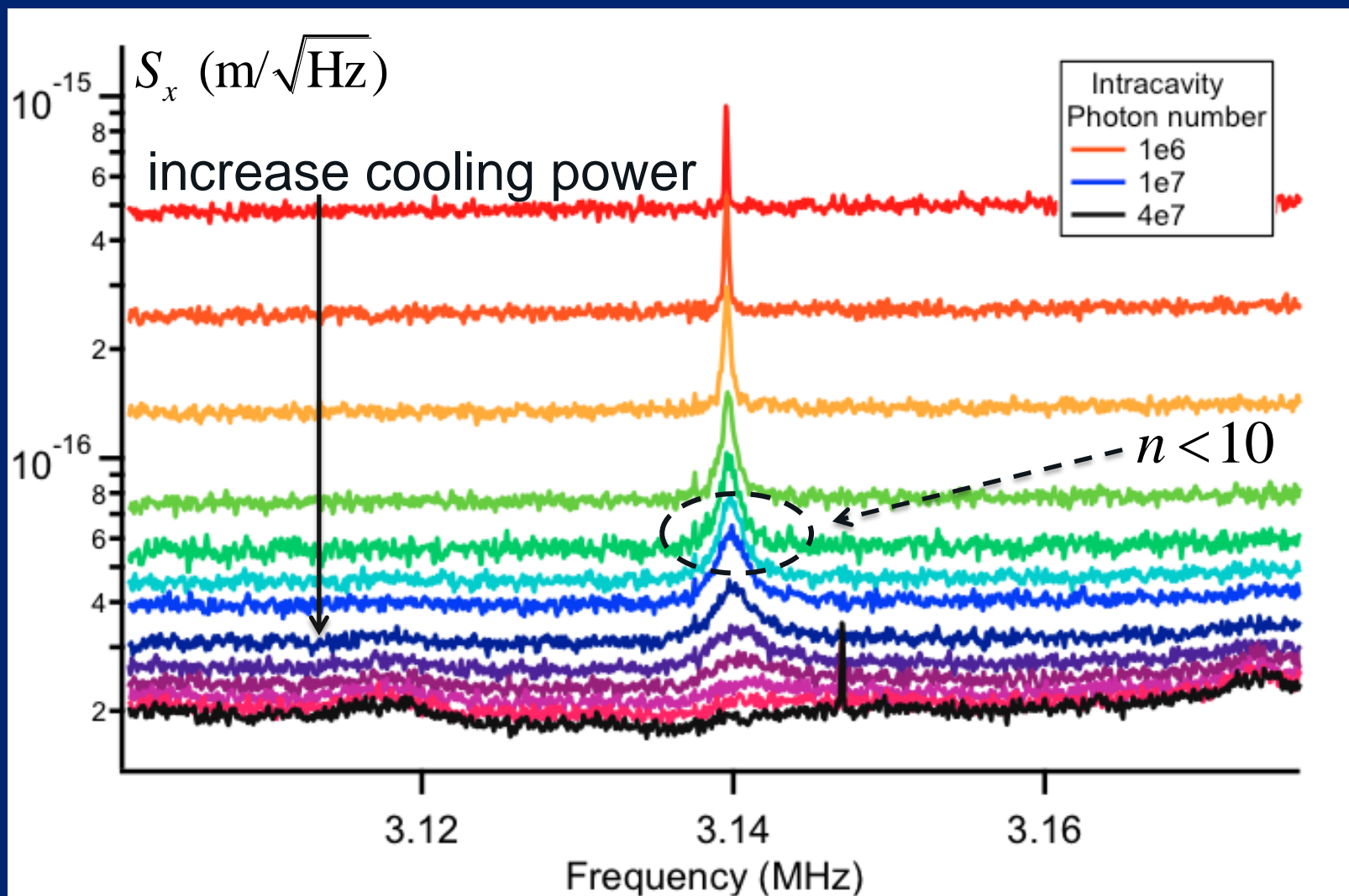

image in cryostat

Membrane motion cooled to near ground state with optical light



Conclusions

- Ground state cooling of a low-frequency mechanical oscillator
- Mechanics: long-lived coherent memory
classical: 10 ms
quantum: 300 μ s (estimate)
- Ultrahigh Q electromechanics with Si_3N_4 membranes
- Opto-electromechanics

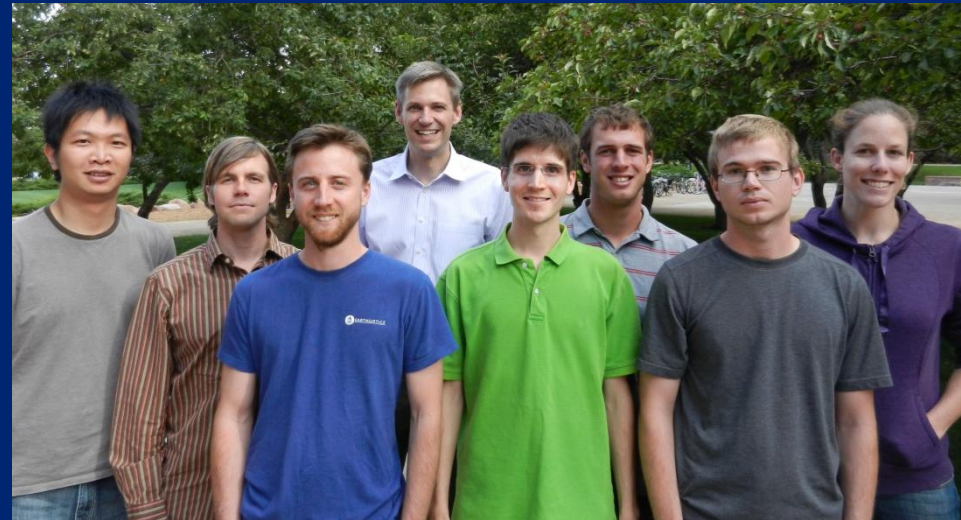

Funding: NSF, NIST, DARPA QuEST, DARPA QuASR, NASA